

MINISTRY OF DIGITAL ECONOMY AND  
ENTREPRENEURSHIP  
(MODEE)

NATIONAL BROADBAND NETWORK

VOLUME 4

REQUEST FOR PROPOSAL  
FOR

FIBER CUTS REPAIR IN (ASEZA REGION & AQABA  
GOVERNORATE)

**RFP #: 10/NBN/2024**  
**PROPOSAL DEADLINE: 23/7/2024**

MINISTRY OF DIGITAL ECONOMY AND ENTREPRENEURSHIP

P.O.BOX 9903 AMMAN 11191 JORDAN

## TABLE OF CONTENTS

<b>1. PROJECT OVERVIEW</b>	<b>4</b>
1.1. INTRODUCTION	4
1.2. SCOPE OF WORK	5
<b>2. WORK REQUIREMENTS</b>	<b>12</b>
2.1. GENERAL	12
2.2. WORKS SERVICES	12
2.3. SERVICE LEVEL REQUIREMENTS (SLR)	12
2.4. REQUIREMENTS AND INSTRUCTIONS	13
2.5. OBTAINING REQUIRED PERMISSIONS	14
2.6. FIBER WORKS PRINCIPLES	15
2.7. CIVIL WORKS PRINCIPLES	18
2.8. WARRANTY	23
<b>3. ANNEXES</b>	<b>24</b>
<b>Annex A:</b> Duct and Joints Specifications	24
<b>Annex B:</b> Chambers Specifications	27
<b>Annex C:</b> Trench Specifications	42
<b>Annex D:</b> Route Crossing	47
<b>Annex E-1:</b> Warning Tape	49
<b>Annex E-2:</b> Electronic Identifiers	50
<b>Annex F-1:</b> Technical Specifications of Optical Fiber Cable - Duct Type	51
<b>Annex F-2:</b> Technical Specifications of Optical Fiber Cable - Aerial Type	60
<b>Annex F-3:</b> Technical Specifications of Optical Distribution Frame	71
<b>Annex F-4:</b> Technical Specifications of Mini Optical Distribution Frame	74
<b>Annex F-5:</b> Technical Specifications of Optical Connectors and Adapters	77
<b>Annex F-6:</b> Technical Specifications of Optical Cable Splice Enclosures	80
<b>Annex F-7:</b> Technical Specifications for Duct Cable Hardware and Support Accessories	86
<b>Annex F-8:</b> Technical Specifications for Aerial Cable Hardware and Support Accessories	88
<b>Annex G:</b> AERIAL CABLE SAG AND CLEARANCE	94

<b>Annex H:</b> Test and Acceptance Specifications _____	95
<b>Annex I:</b> As-Built Specifications for Fiber Installation _____	103
<b>Annex J:</b> Service level Agreement (SLA) _____	108
<b>Annex K:</b> Safety Requirements (EDCO) _____	111

# **1. PROJECT OVERVIEW**

## **1.1. INTRODUCTION**

MODEE through its National Broadband Network Program (NBN) has implemented parts of the NBN Network in Amman, Aqaba Region & North (Irbid, Ramtha & Mafraq) that connects schools, medical centers, hospitals with a Ring that includes Aggregate Points to the NBN, in addition to the government entities which are connected with a Secure Government Network (SGN). Ultimately these regions will be interconnected by an overlay network to complete the “National Broadband Network”.

The Aqaba Special Economic Zone Authority (ASEZA) on behalf of the Ministry of Digital Economy and Entrepreneurship MoDEE is now soliciting proposals from contractors to perform the required work to repair the Fiber Cuts that may take place in the existing Network and to perform any Civil or fiber works required to connect new sites

Where the tasks mentioned above hereinafter shall be referred to as the "Works".

The existing Network consists of:

- **100** locations in ASEZA & Aqaba Governorate.
- **173 km** ADSS (All Dielectric Self Supported) cables hanged on EDCO’s live electrical poles (Electrical distribution Company) within ASEZA Region & Aqaba Governorate.
- **61km** In-Duct fiber cables.
- **37 Km** existing duct routes installed in trenches consisting of a minimum of Two HDPE (High Density Poly Ethylene Pipes) and chambers within ASEZA & Aqaba Governorate.

### **1.1.1. O&M - OPERATIONS AND MAINTENANCE UNIT OF MODEE**

The Operations and Maintenance Unit (O&M) at MoDEE is responsible for the entire program Operations and Maintenance of the Network through its Engineers who will be involved to manage and supervise the contractor’s works.

## 1.2. SCOPE OF WORK

The scope of work consists of the following:

### ➤ **Fiber cable Repair:**

- In order to keep the Network available 100 % all the time, the contractor shall provide a proposal that comply with the below sections for repairing the expected Fiber Cuts that may occur on the existing network or on the new connected entities. The proposal shall comply with the attached Service Level Requirements (SLR) as stated in Annex J to repair the fiber cuts for the inactive Fiber Optic Broadband Network by repairing or supplying and installing all needed materials, cables, fittings, cable mounting accessories, ODF, splicing enclosures, boxes, and optical patch panels,...etc. in addition to the splicing of the cables, the end-to-end testing of installed optical network sections, and all required civil works, including manholes, handholes, pull-boxes and accessories (example : U-Guard, PVC pipes inside entities,.. etc.).
- Payment to the contractor shall be based on a re-measured actual quantities executed for fiber, civil works and installed and other related items in accordance with related unit rates mentioned in the Bill of Quantities (BOQ) in Volume V, noting that all costs incurred by the bidder for all other related items should be included in the bidder's unit rate.

### ➤ **Connecting New Government Sites:**

- The contractor is required to connect new entities to the NBN by performing all the required supply and installation of optical fiber cables, excavations and civil works, all required work to make the transition and extend the fiber from the pole or manhole to the computer lab inside each entity including all needed fittings and accessories to protect and extend the fiber, the supply and installation of all required fittings and cable mounting accessories(Ex: Dead end, Vibration Damper, suspension fittings ...etc), ODF, splicing enclosures, splicing boxes, and optical patch panels, the splicing of the cables, the end-to-end testing of installed optical network sections, in addition to the civil works accessories (ex. U-Guard, PVC pipes inside entities,.. etc.).

### ➤ **Transferring the existing ADSS fiber cable :**

- Transferring the existing ADSS fiber cable is required in case when sections of existing electrical power lines routes are to be modified or rerouted to new poles.
- The contractor is required to Transfer the existing ADSS fiber cable to the new required poles including all related accessories and fittings.
- Transferring the existing ADSS fiber cable to the new poles requires supply and install and splicing of cable including all related accessories and fittings.

- If the existing cable is not suitable to be transferred to new location, the contractor is required to provide new cable according to the prices stipulated in Volume-V.
- The bidder is advised to visit and examine the Site of the Works and its surroundings and to obtain for himself on his own responsibility and expenses all information that may be necessary for preparing the tender and for performing the Works.
- The time of completion for cut repairs shall commence on the day of issuance of the Order to Proceed (OTP) by Modee for the whole of the Works and shall continue for a duration of 730 days.
- All supplied materials shall be new, unused and of high quality approved by the MoDEE's Engineers. Therefore the contractor shall submit not less than 2 samples of the supplied materials to be approved by MoDEE.
- The contractor should use existing material for maintenance work if this material is suitable for use.
- After finishing the maintenance Work the contractor has to keep the old cables, splice enclosures, and all materials and return them back to MODEE.

The Sites to be connected consists of any government entity (school, medical centers, government location).

- The contractor shall be responsible for any needed coordination with all related authorized stakeholders, he is also responsible for all needed route surveys, ROW (Right Of Way), transportation, delivery, installation and testing and all costs incurred shall be included in the Bidder's unit rates.
- The contractor shall coordinate with the stakeholders that have an agreement with the MoDEE for all the needed permits and ROW, this includes: EDCO (Electrical Distribution Company), NEPCO (National Electrical Power Company) and Aseza (Aqaba Special Economic Zone Authority) in Aqaba region. The contractor also shall comply and be aware of all the regulations and safety standards of the above mentioned stakeholders.
- The contract is a re-measured contract based on the actual executed works.
- The route map of the existing Network is shown below in figures 1 & 2.
- The contractor may also recommend alternate routes that comply with both MODEE and authorized stakeholders (Electrical companies, Municipalities, Aseza, Ministry of Public works and Housing (MPWH) ...etc) when needed.

- The Contractor should provide all required maintenance for any defects on the new connected entities for duration of one year as of the date of preliminary acceptance for these works.

**This scope of work describes the Network as per the below technologies:**

1. ADSS cables installed on existing live electrical poles: (medium and low voltage distribution power networks ) as per the MoDEE’s agreement with the concerned authority (Electrical Companies), with all related accessories and fittings (example: ODF, splicing enclosures, splicing boxes and optical patch panels, pigtails, etc...), splicing of the cables, and end-to-end testing of installed optical network. Sufficient spare fiber cable shall be installed within selected poles.

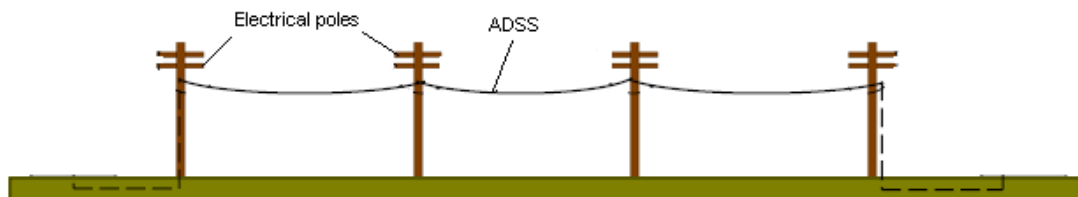

*ADSS Cables hanged on existing electrical poles*

2. In-Duct Optical Fiber cables installed in a HDPE or UPVC ducts in a trenches with all related accessories and fittings (example : ODF, splicing enclosures, splicing boxes and optical patch panels, pigtails, etc...), splicing of the cables, and end-to-end testing of installed optical network. Sufficient spare fiber cable shall be installed within selected manholes.
3. Two or Four or Six HDPE or UPVC ducts installed in trenches with all required civil works, including manholes, handholes, pull-boxes and accessories (example : U-Guard, PVC pipes inside entities,.. etc.) as per specifications.

The trench shall be excavated and backfilled in accordance with the drawings shown below in Annex C.

The total amount of fiber and related civil works are divided into the following lots according to the technologies to be used:

Lot #	Technology	Total existing Length In Aqaba Region
1	ADSS Cables (On Poles)	173Km
2	In Duct Cables	61km
3	Civil works (Trenches)	37 Km

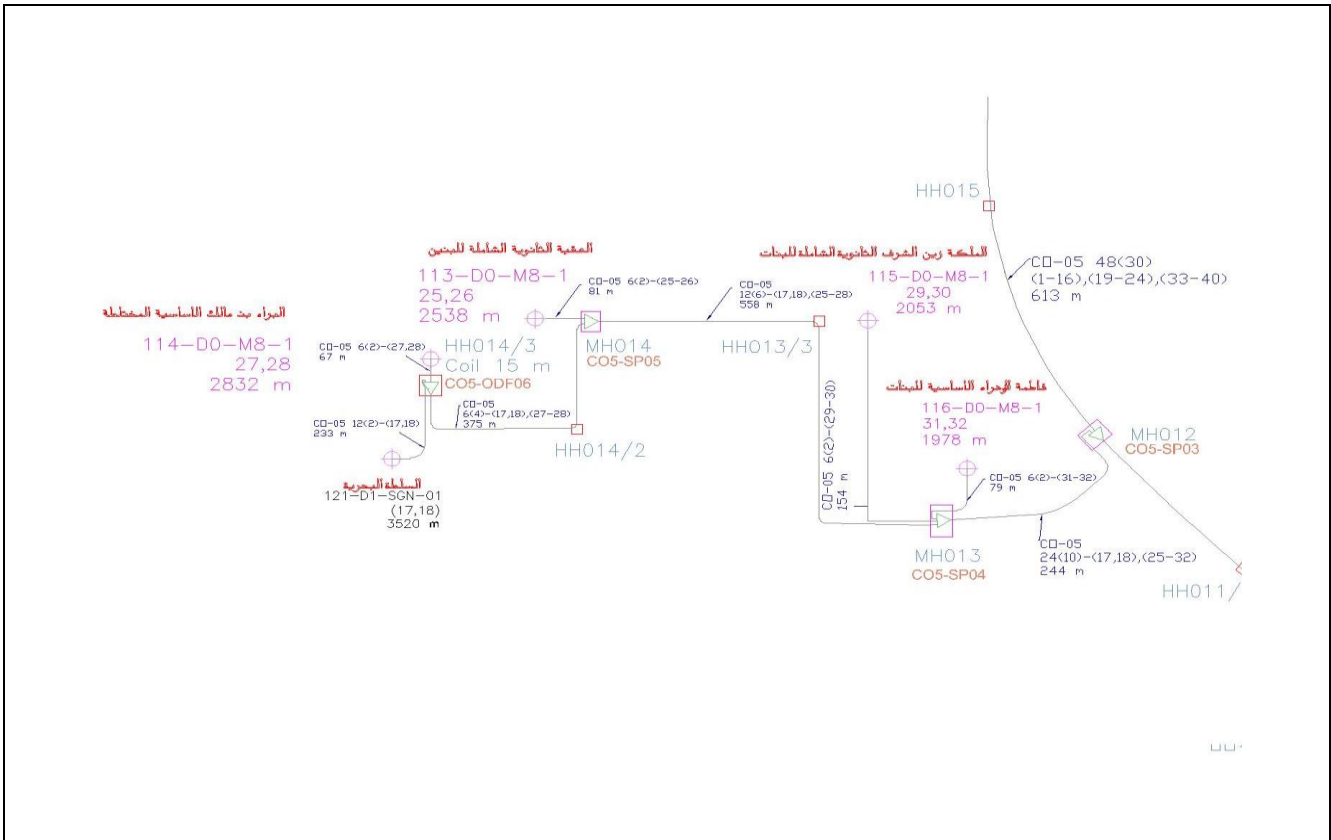

Figure 1: Fiber Routing Plan - ASEZA Region



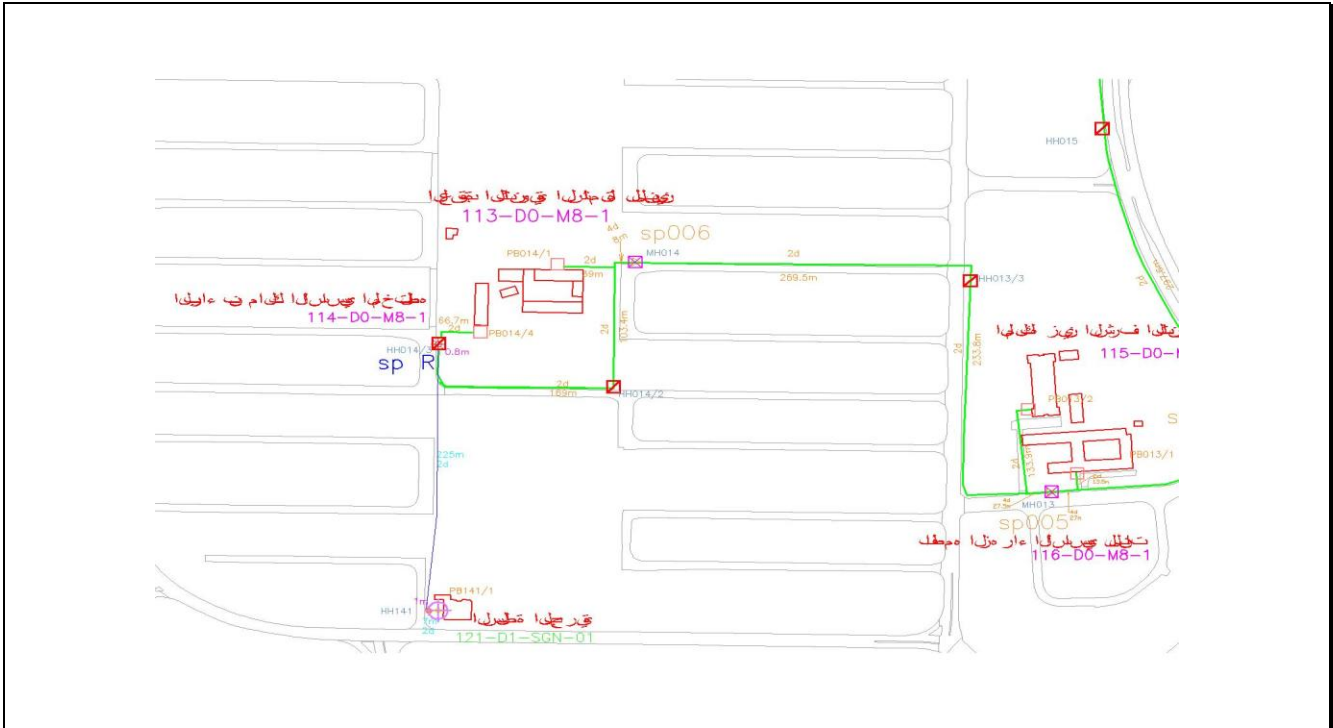

Figure 2:–Civil Work & Fiber Routing Plan–Aqaba Governorate



Figure 3: Civil Works Routing Plan for existing Network of Module 8 - Aqaba Governorate



*Figure 4: Existing Optic Fiber Network – Fiber Routing Plan - ASEZA Region*

The fiber diagrams of the optical network are given in figures, 1, 2, 3 & 4. They consist of a ring structure to interconnect aggregate points. At each aggregate point multiple optical fibers connect the surrounding schools & entities in a star configuration (access network). The ring network was implemented with conventional duct technology. The fiber network between the entities and the aggregate points were implemented with fiber cable installed in ducts or on poles

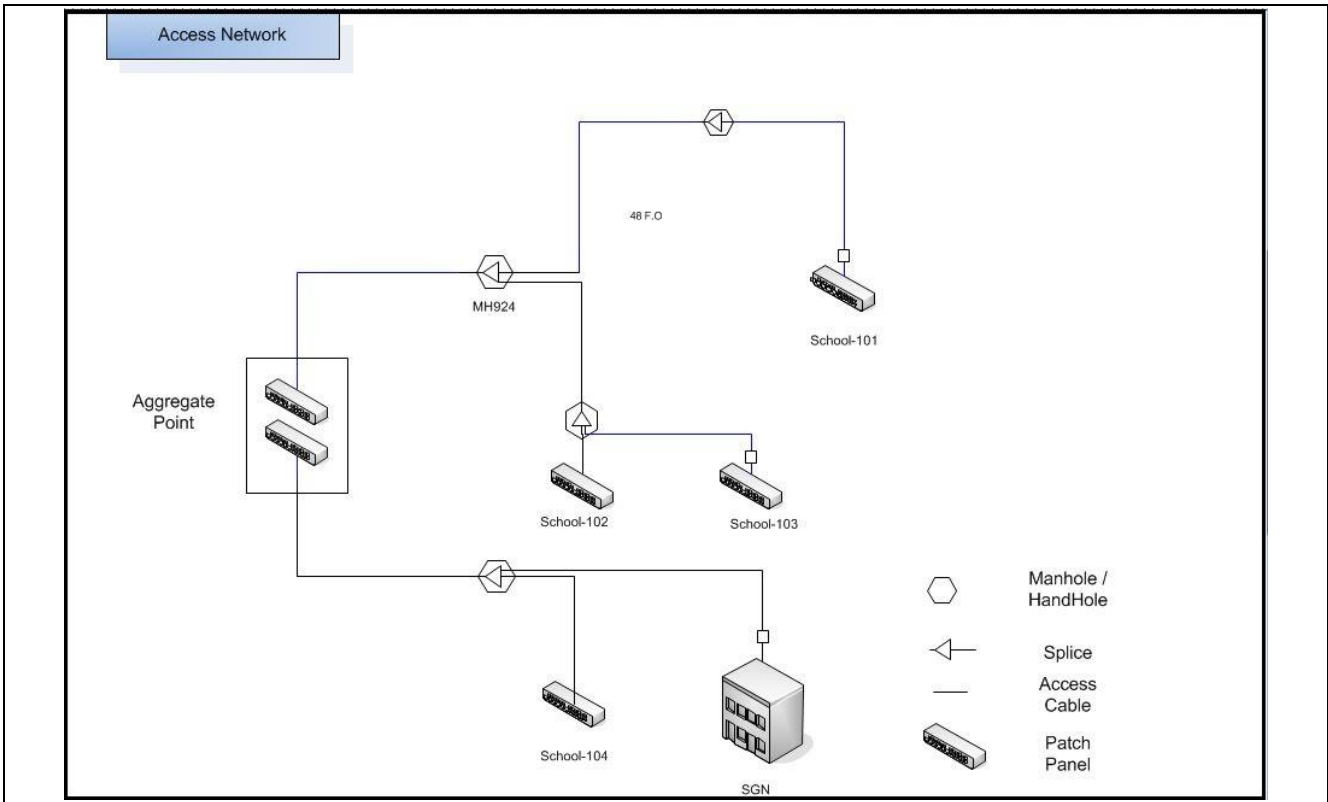

Figure 3: Fiber Optic Cable Arrangement - Access Network

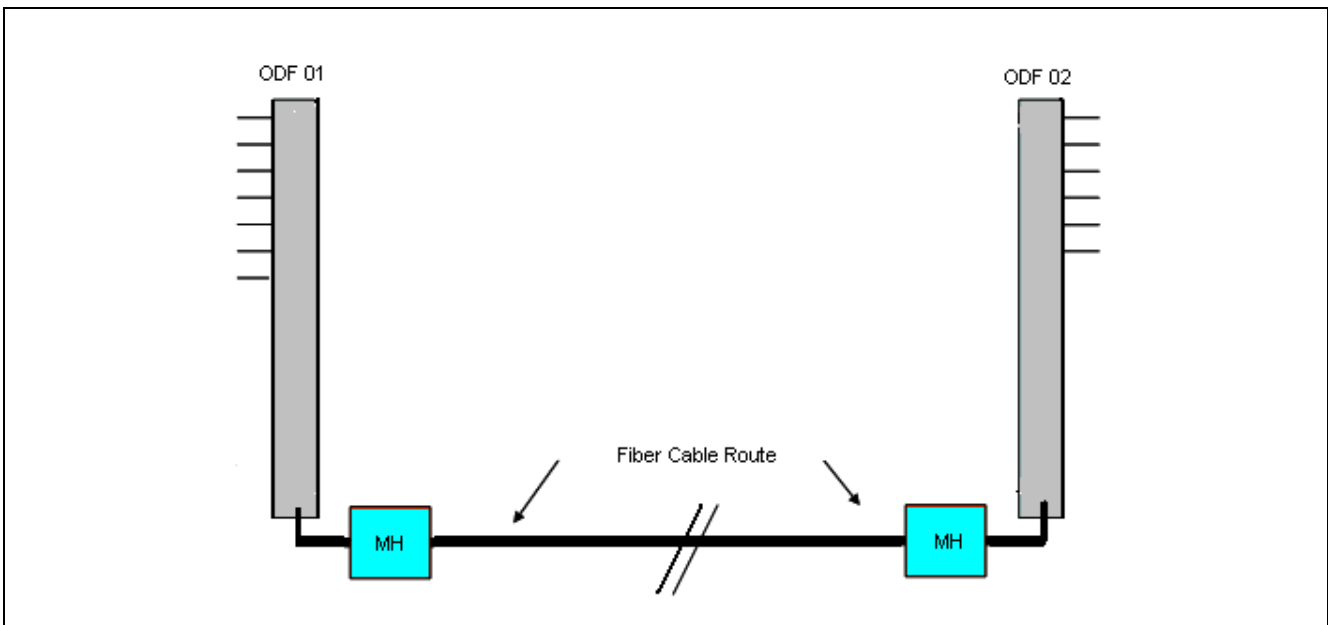

Figure 4: Fiber Optic Cable Arrangement - Connection to Overlay Network

## **2. WORK REQUIREMENTS**

### **2.1. GENERAL**

The bidder shall provide a proposal for all the works stated in the “Scope of work” and the “RFP Document”.

### **2.2. WORKS SERVICE**

- 2.2.1. The Contractor shall submit a Signed Service-Call Report to be sent to MoDEE immediately following every call out, indicating the time of call out visit, cause, remedial action taken and the time that the service was restored.
- 2.2.2. The Contractor's response time and resolution time shall comply with time required in the SLR under Annex I. The response time is defined as the time that elapses between the reporting of a fault and the personnel arriving where the fault is located (with all permits and RoW) as per the SLR Annex.
- 2.2.3. Maintenance Manpower Plan shall demonstrate the Contractor's committed resource level available for all types of activities to be carried out within the cut repair duration. Such plan shall be submitted in the offer.
- 2.2.4. The contractor shall keep the MoDEE updated after starting the works.
- 2.2.5. The Contractor shall coordinate with the stakeholders and carry out safety requirements for the fiber cable installation and repairing in accordance with requirements & regulations.
- 2.2.6. It shall be the responsibility of the contractor to clean the Site all surplus materials, rubbish, temporary works of every kind and leave the whole of the site and installation clean and in a workmanlike condition to the satisfaction of Modee, upon completion of each item of the repair, or do the works.

### **2.3. SLR (SERVICE LEVEL REQUIREMENTS)**

The Contractor’s proposal shall comply with the attached SLR in Annex J to cover at least the following performance terms:

- Emergency level 24/24 7/7 phone support shall be available.
- High-level problem investigation support-must be offered 5/7 during working hours (Jordan time).

## **2.4. REQUIREMENTS & INSTRUCTIONS**

- 2.4.1. Staff and needed equipment items should be determined by the contractor and should be available to comply with the SLR and shall include the following as a minimum :
  - 2.4.1.1. Experienced personnel.
  - 2.4.1.2. All needed equipment to do the works including Suitable crane.
  - 2.4.1.3. All needed equipment to the tests and report them to the ministry.
  - 2.4.1.4. All needed equipment's, materials or machines to execute the civil or fiber works including the ADSS cables.
- 2.4.2. The contractor shall submit for the Engineer's approval samples and specification documents, datasheets & catalogues for all components of the passive optical fiber network upon receipt of the OTP (Order to proceed). No works can commence prior to receipt of the approval issued by the Engineer or by delegated authority by the Engineer. All works shall apply to good engineering standards.
- 2.4.3. All supplied ADSS accessories should be fit to EDCO medium and low voltage poles.
- 2.4.4. Cable installation should be according to cable specifications sheet attached to the Fiber cable Drum.
- 2.4.5. The Contractor is responsible for the quality of the supplied materials required for the works and shall present samples and data sheets of the materials for approval by the Engineer. (This includes optical fiber cable, pigtails enclosure, splice boxes, ODFs, shelves for ODF, optical patch panels, ADSS cable, accessories, duct materials, chambers, covers, joints, duct labels, cover labels, detection/warning tape etc.. ) The supply and installation of all materials is in accordance with the specifications. Accessories shall be purchased from the cable manufacturer or purchased from vendors specialized in manufacturing such accessories.
- 2.4.6. The contractor shall take all the necessary steps to ensure that the cable is properly packed to avoid any possible damages to the cable during transportation.
- 2.4.7. . The contractor shall determine the fault and accurate location of the fault using OTDR and VFL.
- 2.4.8. The Contractor advises the MoDEE as soon as possible (after checking that the cable link and not the equipment is the cause of fault). This means that the contractor representative should be able to contact the MoDEE's maintenance manager even at night or during public holidays.
- 2.4.9. Repair - if necessary after digging of a trench, re-installing of cable and splicing for the In-Duct routes.
- 2.4.10. When connecting a new entity the contractor shall do the following :
  - 2.4.10.1. Survey the planned path for the New Routes.
  - 2.4.10.2. Propose the final path of the route to the Engineer for approval.

2.4.10.3. Deliver detailed drawings to MoDEE Engineer “Plan-to-build”/“Shop Drawings” suitable for the RoW applications and also suitable for the subcontractors to perform the construction works. The electronic format of these drawings should be compatible with GIS (ESRI format). These detailed drawings should also form the basis for the as-built drawings.

2.4.10.4. The Contractor will supply to the MoDEE a full set of as-built drawings of the Executed Works not later than two (2) weeks after the provisional acceptance. Such drawings shall be in accordance with the Specifications set forth in Annex H and should be delivered in electronic format compatible with GIS (ESRI format) on CD-ROM.

## **2.5. OBTAINING REQUIRED PERMISSIONS**

Contractor shall provide the following services in connection with obtaining the permissions to do the works for the civil and fiber works:

- (1) The Contractor shall file, with all competent authorities, stakeholders (including Aseza & EDCO) and private (non-governmental) persons, complete and accurate applications for all permissions necessary or appropriate to obtain the permits to do the works, including splice boxes and other required ancillary equipment along the route in accordance with the legal conditions applying to the permits. All applications should be finalized in due time including Access sites connectivity. Copies of the permit applications for the whole route must be forwarded to the Ministry.
- (2) The Contractor shall as soon as reasonably feasible inform MoDEE of any proposed modification of the Route thereby indicating the reason for the modification, the potential consequences of the additional length or reduced length of the Route for the right of way, and the MoDEE shall respond to such proposal accordingly.
- (3) The Contractor shall duly follow up on such applications and to the extent necessary or appropriate, meet with competent authorities or persons (both prior to and, if necessary, after the filing of the applications), assist at any level of the procedure (e.g. take recourse against possible refusal, etc.) and revise or file new applications as a consequence of comments or suggestions received from competent authorities, the Engineer or private landowners. The Contractor shall provide the Ministry with the permits which comprise any forms of legal co-operation (including without limitation easements, servitudes, leases, access rights) by third (non-governmental) persons and all permits, licenses and other approvals or authorizations of any municipal or administrative agency or authority (including such forms of legal co-operation, collectively, permits) necessary or appropriate to enable installing the optical fiber cable and all related telecommunications infrastructure along the route in accordance with the legal conditions applying to the permits. The permits shall meet the requirements to install fiber optic cables. The permits will enable to install splice boxes, hand-holes, etc. and fiber

optic cables along the whole route. Copies of the granted permit documents shall be forwarded to the Engineer within 3 working days after receipt of the grant.

## **2.6. FIBER WORKS PRINCIPLES**

### **2.6.1. General Fiber Works Principles :**

- 2.6.1.1. After finishing the works, the optical attenuation between the affected termination points will be measured in accordance with the procedure and acceptance criteria of Annex H.
- 2.6.1.2. Optical time domain measurements will be carried out to verify the quality of splicing of optical fibers. This will be executed in accordance with the procedure and acceptance criteria mentioned in point-3 of Annex H.
- 2.6.1.3. Optical dispersion and PMD measurements (factory sheet) of each cable drum used for the optical network shall be presented to MODEE for verification. The acceptance criteria are specified in Annex H.
- 2.6.1.4. Optical termination points should be protected by removable high quality caps.
- 2.6.1.5. Duct and cable terminations into buildings should be properly sealed and protected. Sealing should be of high quality and UV-light resistant.
- 2.6.1.6. Cable terminations or cable transitions should be clearly labelled with weather and UV-resistant labels in accordance with the fiber allocation table supplied by MODEE.
- 2.6.1.7. All ducts and fiber optics should be visibly labelled with long lasting labels, with supplying a proper references material to reflect the locations of them.

### **2.6.2. ADSS Fiber Works Principles:**

- 2.6.2.1. It is required that the entire section between the closest two existing joints be replaced.
- 2.6.2.2. Any other repair arrangements or recommendations require MoDEE's approval based on a proposed design provided by the contractor to carry out the repair.
- 2.6.2.3. All installed and repaired accessories should comply with the existing accessories installed and Type of cable storage system, as instructed by the engineer (MODEE).
- 2.6.2.4.
- 2.6.2.5. The Contractor will install all optical fiber and optical passive components to deliver optical connectivity from termination to termination point. In addition, the Contractor will test and verify the connectivity between the optical termination points as stated in Section 2.4.
- 2.6.2.6. When installing enclosure the contractor shall test all the strands in the cable in one direction according to the instructions of the engineer (MODEE)

### 2.6.2.7. Cable Hardware:

1. **Pass-Through Bracket (Fiber Optic Tangent):** Used as cable suspension hardware only when the angle of change, either horizontal or vertical, is less than  $15^\circ$  .
2. **Armor Grip Suspension:** Used for any span length with an angle change, either horizontal or vertical, less than  $30^\circ$  .
3. **Fiber Optic Dead-end Grip:**
  - A dead-end is installed at each end of the cable length to attach to the structures. Two dead ends are used at angle changes of  $30^\circ$  or greater, either horizontal or vertical. If the structures are in-line but have a vertical difference greater than  $20^\circ$  , dead ends shall be used to distribute the cable through the incline/decline.

- **Road Crossing:**

You should be use the suspension rod and protection rod

ADSS-Fittings for Span Field Lengths < 70 m

- **Suspension with suspension rods, ring type thimble and supporting rods**



- **Tension with helical dead end and thimble**



### ADSS-Fittings for Span Field Lengths 70 - 150 m

- **Suspension with suspension rods, ring type thimble, supporting rods and vibration damper**





- **Tension with helical dead end, thimble and vibration damper**

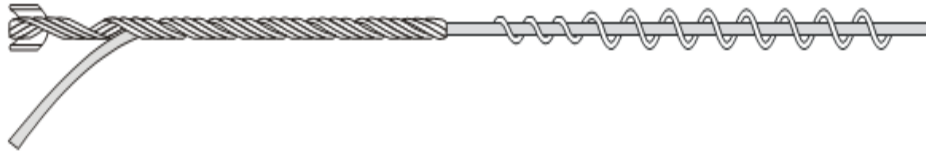

### **ADSS-Fittings for Span Field Lengths > 150 m**

- **Suspension with armor grip suspension and long span vibration damper**

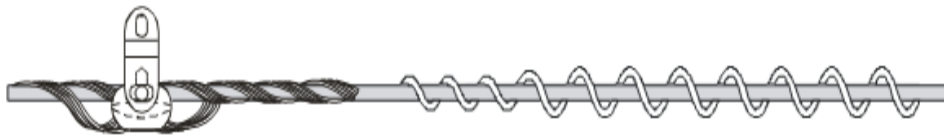

- **Tension with shackle, thimble, helical dead end, protection rods and long span vibration damper**

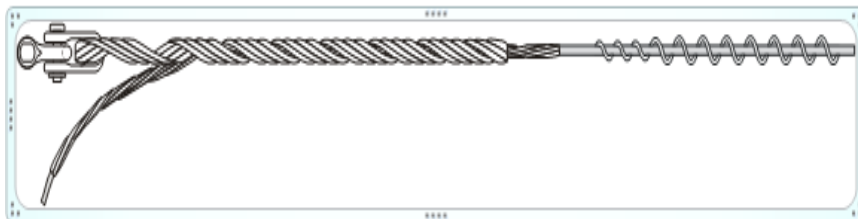

Specifications and images are stated in Annex *F-8*.

#### **2.6.3. In Duct Fiber Works Principles:**

- 2.6.3.1. The repairing includes cutting the affected cable and; replacing it with a new cable (inside the repaired ducts ) and proceed with the required splicing, which could be accomplished using one or two cable splices depending on the location of the cut relative to the existing splice.
- 2.6.3.2. Any other repair arrangements or recommendations require MODEE's approval based on a proposed design provided by the contractor to carry out the repair.
- 2.6.3.3. All installed and repaired accessories should comply with the existing accessories installed.

#### **2.6.4. Fiber Works Acceptance Testing:**

The Contractor will invite the MODEE with at least 3 days advance notice to witness the acceptance testing of the installed fiber in accordance with the SLR mentioned in Annex G. Invitation for acceptance testing should only be forwarded to the MoDEE after the Contractor has successfully executed internal acceptance tests. Acceptance test will be carried out between optical termination points (ODF, patch panels) and witnessed by the appropriate representatives from the MODEE.

- 2.6.4.1. The length between optical termination points shall be verified and will be compared with the "plan-to-build"/"shop" drawings. Significant changes will be indicated and the Contractor shall specify the differences in length. Major deviations can lead to non-acceptance of the route or parts of the route.
- 2.6.4.2. The optical attenuation between the termination points shall be measured in accordance with the procedure and acceptance criteria of Annex G.
- 2.6.4.3. Optical time domain measurements shall be carried out to verify the quality of splicing of optical fiber cables. This will be executed in accordance with the procedure and acceptance criteria of Annex G.
- 2.6.4.4. Optical dispersion and PMD measurements (factory sheet) of each cable drum used for the optical network shall be presented to the Employer for verification. The acceptance criteria are specified in Annex G.
- 2.6.4.5. Optical termination points should be protected by removable high quality caps.
- 2.6.4.6. Duct and cable terminations into buildings should be properly sealed and protected. Sealing should be of high quality and UV-light resistant.
- 2.6.4.7. Cable terminations or cable transitions should be clearly labeled with weather and UV-resistant labels in accordance with the fiber allocation table supplied by the Engineer.

#### **2.7. CIVIL WORKS PRINCIPLES:**

The Contractor should be aware of the specifications and regulations of ASEZA and Aqaba Governorate regarding the excavations and backfilling in Asphalt or In Side-walks and their regulations should be obeyed, in addition to the following:

- (1) The Contractor will supply all materials required for the Works. The Contractor is fully responsible for the quality of the supplied materials. This includes duct materials, chambers, covers, joints, cover labels, warning tape, etc.
- (2) The Contractor is fully responsible for the construction site and safety on the construction site. The Contractor shall apply for any permit required (e.g. road blockage, police permission, Aseza or EDCO's permission and all concerned authorities) for executing the works and shall be fully compliant with the regulations of all local and governmental authorities.

- (3) The Contractor will maintain a progress report and incident report for the new executed routes and the Fiber Cuts.
- (4) The Contractor does not have the right to claim the working space excavations in addition to re-instate these excavations. The Contractor does not have the right to claim for any additional cost related to supporting the trench walls.
- (5) The execution of trench excavation for fiber optics cables 50cm wide and 100cm deep regardless of the type of the soil, and the terrain has to be re-instated to its original status. The longitudinal excavation has to be as directed by Governmental/local laws and the Supervising Engineer.
- (6) The trench constructions will be executed according to the specifications in Annex C. In case where the proposed cross section as detailed in the afore mentioned specifications, cannot be achieved and the cover of sand and pavement above the ducts is less than 60 cm, concrete protection plates or slabs should be used (concrete with a minimum cube crushing strength of 200 kg/cm<sup>2</sup> after 28 days and 20cm thickness without additional cost to MODEE).
- (7) Backfilling with Sweileh sand to protect the pipes, not less than 30cm high.
- (8) Refill of the trench should be free of stones or other sharp objects, and should not contain polluted sand or organic materials. **The excavated material shall never be used in backfilling.** Single size material should be used on top of the Sweileh sand, in accordance with the requirements of the authorities and related specifications.
- (9) Asphalt cutting should be executed rectilinear by using special machines.
- (10) For Asphalted surfaces, a base course layer of 30cm should be applied above the single size at a compaction rate of not less than 97 %. The Asphalt layer should be not less than 7cm thick after compaction, and the compaction degree should not be less than 98% according to Marshall Test. A layer of MC-70 should be applied on the base course prior to Asphaltting, at 1.5 kg/m<sup>2</sup>, to protect the base course, including the sides of the trench. Or as instructed by ASEZA.
- (11) The following should be applied on the complete road crossings:
  - Well compacted cement treated base course layer (120kg of cement/m<sup>3</sup>), or concrete layer (as required by the responsible authorities) with 40cm thickness should be applied underneath the Asphalt. Or as instructed by ASEZA.
- (12) The warning tape must be of yellow color with the text given in Annex E-1 and such text is repeated every 1m. Its width should be 15cm. the material of the warning tape should be submitted to the Engineer for approved prior to the ordering process and should be placed at a distance not more than 30 cm from the finish floor level or as directed by the supervising Engineer.
- (13) A plastic rope of 6mm diameter should be installed in each duct, using different colors for each duct, for cable pulling purposes. The rope shall be one continuous peace from manhole to manhole, no knots are allowed.

- (14) Bridge crossing will be implemented after permission from the concerned authorities by installing the ducts inside 6 inch protective galvanized steel pipe along the edge of the bridge as shown in Annex D and as required by the responsible authorities.
- (15) Railways crossing will be implemented after permission from railway authorities by installing ducts inside 6 inch protective galvanized steel pipe according to the specifications of the national railways company (Jordan) as shown in Annex D.
- (16) Installation of the ducts should be executed rectilinear and in the center of trench. The ducts will be sealed at each end of chamber to avoid the entry of dirt. The identification label printed on exposed ducts every one meter and will contain the text **“MODEE-NBN”**.
- (17) Ducts shall be terminated flush to manholes, hand holes, and pull boxes; edges shall be leveled off. Ducts entering manholes, hand holes, and pull boxes shall be plugged and watertight. The plugging mechanism or material shall be readily removable to allow for future cable installation. Ducts shall enter manholes, hand holes, and pull boxes at 90 degree to the structure's wall using core cutting machine. After the installation of the cable inside duct, the duct shall be tightly sealed with foam. The spare ducts shall be plugged with a removable plug material to allow for future cable installation as shown below.



- (18) The trench system consists of: TWO or FOUR SIX HDPE tubes UPVC subducts installed inside UPVC main duct between manholes, hand holes and pull boxes according to the specifications and drawings in Annex C ,as instructed by the engineer(MODEE).
- (19) All samples should be forwarded to the MODEE for official approval before purchasing. No construction work can commence prior to receipt of the approval issued by the MODEE. All construction works should apply to good engineering standards and in agreement with the most recent civil and architectural construction specifications issued by Ministry of Public Works and Housing and the requirements of concerned authorities.
- (20) The Contractor is fully responsible for the quality of the supplied materials. This includes duct materials, chambers, covers, joints, duct labels, warning tape, etc.
- (21) The trench should be excavated in lines as far as possible and bends should have a radius in excess of 200 cm. The trench should be leveled as much as possible and sharp objects (stones, glass, etc.) should be avoided or removed from the trench.

Other cables or infrastructure should be under passed as far as possible. The security distance dictated by NEPCO and EDCO in trenches to High Voltage power lines should be respected.

Pre-cast chambers or manholes will be installed according to the technical specifications in Annex B. The trench for the manhole will be excavated 20cm deeper at the position of chambers and this 20cm will be filled with stabilization sand. The cover of the chambers needs to be leveled with the pavement, road or surrounding terrain, and the backfill around chambers should be of single size materials. The distance between chambers/manholes should not exceed 300m.

### **Manholes:**

- The pre-cast manholes (120cm(L)\* 68cm(W)\* 82cm(D)) as internal dimensions with a base and walls of 15 cm thickness, with a fair-face surface finish made from reinforced concrete with minimum cube crushing strength of 250 kg/cm<sup>2</sup> and 7Ø10 mm/m steel bars in both directions for walls and base.
- The manholes shall be equipped with terminators, galvanized pulling eyes, step, cable support, brackets, marker plates in addition to frame, steel mesh and all accessories required to fix the splicing enclosures and spare cable loop mounting.
- The two covers shall be of the heavy duty cast iron type with a label stating “MODEE-NBN”. The covers shall be lockable, and bear a 40 tons load.

### **Ring Manholes**

The manholes ring (with diameter 90cm & depth 90cm) as minimum internal dimensions with a base and Wall of 10 cm thickness, with a refined surface made from reinforced concrete with fracture strength of 250 kg/cm<sup>2</sup>.

The manholes ring shall be equipped with steel mesh terminators, galvanized pulling eyes, step, cable support and brackets, marker plates, frame and complete hardware package.

The Manhole ring cover shall be of the heavy duty cast iron type with a label stating “MODEE-NBN”. The covers shall be lockable. And bears 40 ton.

### **Hand Holes:**

- The pre-cast Hand holes (91.5\*46\*82 cm) as internal dimensions with a base and walls of 15 cm thickness, with a fair-face surface finish made from reinforced concrete with a Minimum cube crushing strength of 250 kg/cm<sup>2</sup> and 7Ø10mm/m steel bars in both direction for walls and base.
- The Hand holes shall be equipped with terminators, galvanized cable support and bracket, marker plate, frame, steel mesh and all accessories required for splicing enclosures and spare cable loop mounting.
- The cover shall be of the heavy duty cast iron type with a label stating “MODEE-NBN”.
- The cover shall be lockable, water tight, and bear a load 40 tons.

**Pull Boxes:**

- The pre-cast pull boxes (50\*25\*50cm) as internal dimensions with a 5 cm thickness for the base and walls, and 10cm for the cover with a fair-face surface finish made from reinforced concrete with a Minimum cube crushing strength of 200 kg/cm<sup>2</sup>.
- The cover shall be of reinforced metallic type.
- The pull boxes include: the cover, a marker plat (fixed on the entity's wall near the Pull Box), and finishing.

**2.7.1. Civil Works Acceptance Testing**

The Contractor will inform the ministry with at least 3 days advance notice to witness the acceptance testing of the constructed route. Invitation for acceptance testing should only be forwarded to the Engineer after the Contractor has successfully executed internal acceptance tests. Acceptance test will be carried out between chambers and witnessed by the appropriate representatives from the MODEE.

- 2.7.1.1. Chambers (manholes) should be of the same type as indicated in the technical specifications and drawings and approved by the Supervising Engineer. The chambers should have been installed free of dirt and water on the inside. Covers should fit correctly and should be locked. The duct feed troughs should be correctly mounted and ducts shall be terminated flush to the chamber structure. Chamber label should be marked on the inside.
- 2.7.1.2. The route length between chambers shall be verified and will be compared with the plan-to-build/shop drawings. Significant changes will be indicated and the Contractor shall specify the differences in length. Major deviations can lead to non-acceptance of the route or parts of the route.
- 2.7.1.3. The ducts shall be cleaned on the inside by blowing air at low pressure from one chamber to the next chamber. After cleaning mandrill will be used with a length of 150 mm and with 5 mm smaller diameter as the inside duct diameter. The mandrill should pass without any obstacles and no crossing of duct numbering should occur.
- 2.7.1.4. The Contractor shall execute the tests and provide an acceptance test report to the Engineer to summarize the test results from chamber to chamber for each system and duct. This acceptance report will be signed by representatives from the Contractor and the Engineer only in case of successful acceptance. The cost for this testing cannot be claimed separately.

## **2.8. WARRANTY**

- a) The contractor shall provide as a minimum one year of warrantee of the manufacturer defect warranty starting from the date of handing over and acceptance for the new added entities.
- b) The contractor warrants that the materials supplied under the contract are new, unused, and those they incorporate all recent improvements in design and materials unless provided otherwise in the Contract.
- c) The contractor further warrants that all materials supplied shall have no defect, arising from design, materials, or workmanship or from any act or omission of the Supplier, that may develop under normal use of the supplied materials in the conditions prevailing in Jordan
- d) MoDEE shall promptly notify the contractor in writing of any claims arising under this warranty.
- e) Upon receipt of such notice, the contractor shall, within the specified period and with all reasonable speed, repair or replace the defective materials or parts, without additional costs
- f) If the contractor, having been notified, fails to remedy the defect(s) within the period specified above, the MoDEE may proceed to take such remedial action as may be necessary, at the contractor's risk and expense and without prejudice to any other rights which the MODEE may have against the Supplier under the Contract.

### 3. ANNEXES

#### ANNEX A: DUCT AND JOINTS SPECIFICATIONS

##### HDPE:

The supplied ducts must conform to the specifications below. Please note that these specifications apply to High Density Poly Ethylene ducts of 40 mm outside diameter.

The color of the ducts shall be blue.

The print on the outside shall be in resistant black print “MODEE-NBN” at a spacing of every 100 cm.

PE Duct Specifications			
S.N.	Description	Unit	Value
1.	Tensile Strength	N/MM <sup>2</sup>	MIN - 20
	Elongation	%	MIN - 350
2.	Reversion	%	MIN - 350
3.	Impact Strength	Kg	The duct shall not crack or split (At 10 Kg. Load)
4.	Crush Resistance (The Deflection with Load)	%	≤ 10
	The Deflection after Recovery	%	≤ 2
5.	Mandrel Test		The Mandrel shall be passed freely through a 5 meters length of duct, when the duct is bent to a radius of 5 meters
6.	Oxidation Induction Test	Minutes	> 30
7.	Internal Coefficient of Friction		Not More than 0.06
8.	Melt Flow rate (at 5 kg, 190° C)	gm/10 min	0.2 to 1.1
9.	Density (Finish Product)	gm/cc	0.940 To 0.958
10.	Hydraulic Characteristics At temp 80° C		The Sample shall not show sign of localized swelling or leakage & shall not burst during the test period
	Type Test	Test Duration	Induced Stress
	Acceptance Test	165 Hrs.	3.5 Mpa
		48 Hrs.	3.8 Mpa

Standard dimensions (OD/ID)	Tolerance on wall thickness	Co-efficient of friction
40/33 mm	± 0.2 mm	< 0.06



The joints for these ducts must fit the exact inside and outside diameter and must be full waterproof.

Use compression joints that can be shifted over the HDPE tube and compress the two parts together when screwing the joint together. Compression joints are easy to handle and do not require additional tools or material.



*Duct Coupler (HDPE to HDPE)*

## **UPVC:**

- We also use UPVC Duct system of fiber optic network consisting of One or two main UPVC duct 4 inches in diameter & 3.2mm thickness each containing, Two or Four UPVC sub-ducts (32mm in diameter & 1.8mm thickness) according to the specifications and drawings in annex C.
- The color of the UPVC ducts shall be Yellow and The print on the outside shall be in resistant black print “وزارة الاقتصاد الرقمي والريادة-MODEE-NBN” at a spacing of every 100 cm.
- Specifications must be available in plastic pipes (vinyl chloride) used in communications networks buried underground as follows:
- **Duct Specifications:** المواصفات الفنية لمواسير البلاستيك
- The supplied ducts must conform to the specifications below.

### **1 المجال ونطاق التطبيق : Scope & Field of Application**

تختص هذه المواصفات الخاصة بمواسير البلاستيك غير المدن (متعدد كلوريد الفينيل) ذات المقاس الاسمي (1.25inch و 4 inch) والمستخدمه بمشاريع شبكات كوابل الاتصالات المدفونة تحت الأرض.

## 2 الخصائص: Characteristics.

يجب أن يتوفر في المواسير البلاستيكية (متعدد كلوريد الفينيل) المستخدمة في تمديدات شبكات الاتصالات المدفونة تحت الأرض ما يلي:

### أ. مواد التصنيع: Materials.

- (1) أن تصنع أساساً من متعدد فلوريد الفينيل غير الملدن (UPVC).
- (2) أن لا تحتوي على أية إضافات عدا إضافة اللون والإضافات الضرورية لتسهيل عملية تصنيع المواسير لإنتاج مواسير سليمة ومعتمة ذات أسطح ناعمة وذات متانة ميكانيكية جيدة (وقد يضاف إليها مرتجعات نظيفة من نفس عملية التصنيع ونفس المنتج وتفي بمتطلبات هذه المواصفة ولا يجوز استعمال أي مرتجعات أخرى).

### ب. المظهر والحالة العامة: Appearance.

- (1) أن تكون جدران المواسير مستقيمة وذات مقاطع دائرية ولون اصفر.
- (2) أن تكون جدران الأنابيب والأسطح الداخلية والخارجية ناعمة خالية من التشققات والشروخ والتجاعيد الحادة الأطراف والبقع والفرغات أو أية عيوب أخرى أو مواد غريبة (ويسمح بالتجاعيد الخفيفة المنبسطة).

### ج. الكثافة: Density.

ألا تقل كثافة المواسير عن 1.35 سم<sup>3</sup>/غم ولا تزيد عن 1.45 غم/سم<sup>3</sup> عند درجة حرارة 23 درجة مئوية.

### د. الأبعاد والتفاوتات: Dimensions and Tolerances.

- (1) أن يكون الطول الفعال (بدون المفة) للماسورة 6 متر وألا يتعدى التفاوت في الطول على (صفر - 30) مم.
- (2) أن يكون الحد الأدنى للأقطار الخارجية ولسمك الجدران والتفاوتات كما هو موضح بالجدول رقم (1) و (2).

### جدول رقم (1)

القطر (مم)		السمائة (مم)		المقاس الاسمي
الحد الأعلى	الحد الأدنى	الحد الأعلى	الحد الأدنى	
32.2	32	2.2	1.8	32 مم
110.3	110	3.8	3.2	110 مم

### جدول رقم (2)

السمائة (مم)		طول المفة (مم)		المقاس الاسمي
الحد الأعلى	الحد الأدنى	الحد الأعلى	الحد الأدنى	
2.2	1.8	88.0	80.0	32 مم
3.8	3.2	121	110	110 مم

- (3) يجب أن يكون طرف الأنبوب الخالي من المفة مشطوفاً Beveled لمسافة 3مم على السطح الداخلي للأنبوب.

### هـ. مقاومة الصدم: Impact Resistance.

أن تجتاز المواسير اختبار الصدم عند درجة حرارة 20 درجة مئوية ولا تزيد النسبة المئوية المكسورة على 10% من مجموعة العينات.

The joints for these ducts must fit the exact inside and outside diameter and must be full waterproof.

# ANNEX B: CHAMBERS SPECIFICATIONS

## ❖ Manholes with Magnetic Metallic Cover

The manholes (120\*68\*82 cm) as minimum internal dimensions with a base of 15 cm thickness, with a refined surface made from reinforced concrete with minimum cube crushing strength of 250 kg/cm<sup>2</sup>. The manholes shall be equipped with terminators, galvanized, step, cable support and brackets, marker plates, frame, steel mesh and complete hardware package. The covers shall be of the heavy type.

The two covers shall be Metallic and Magnetic with a label stating “MODEE-NBN the covers shall be lockable. And bears 40 ton

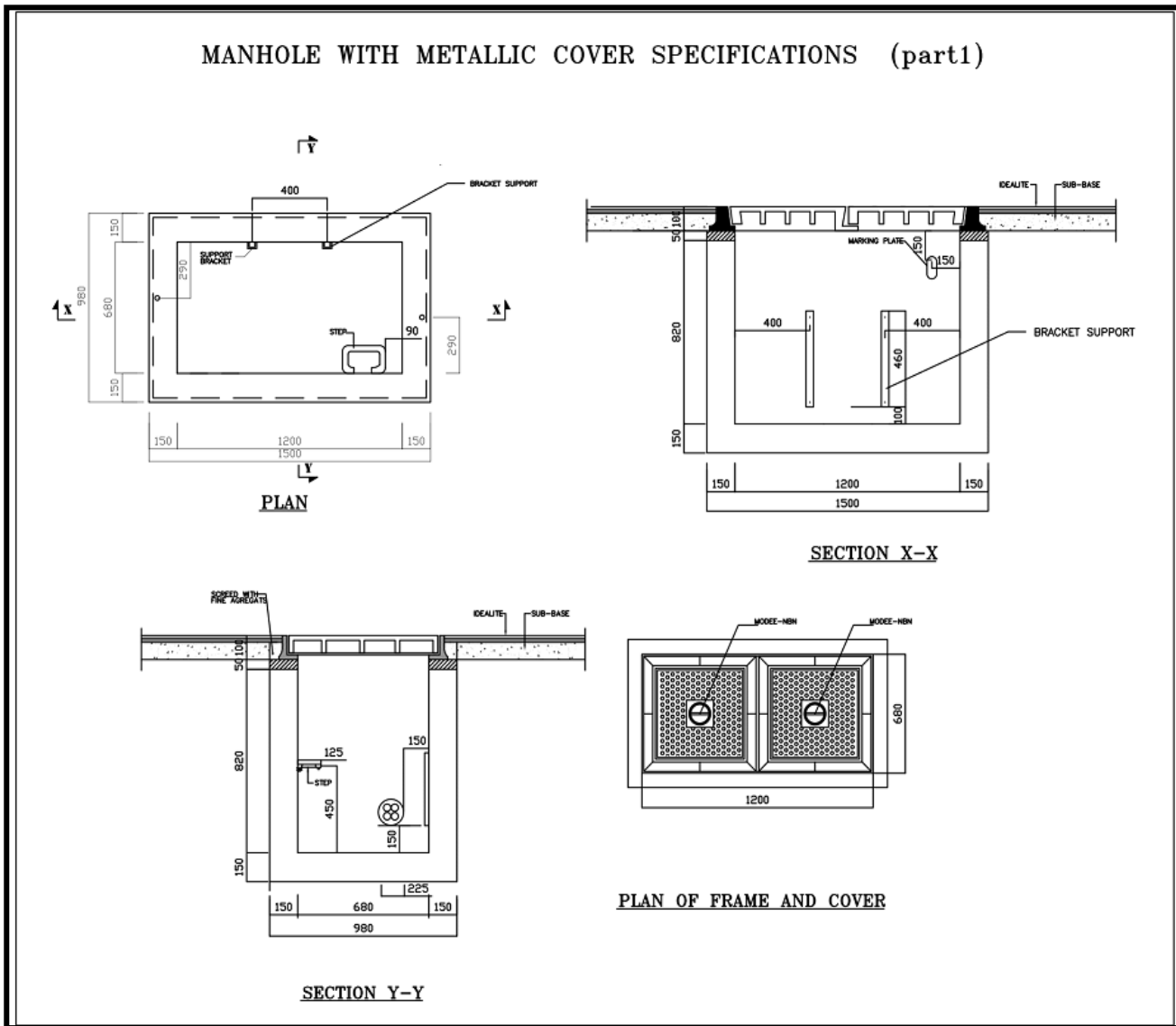

# MANHOLE WITH METALLIC COVER SPECIFICATIONS (part2) ...Cont'd

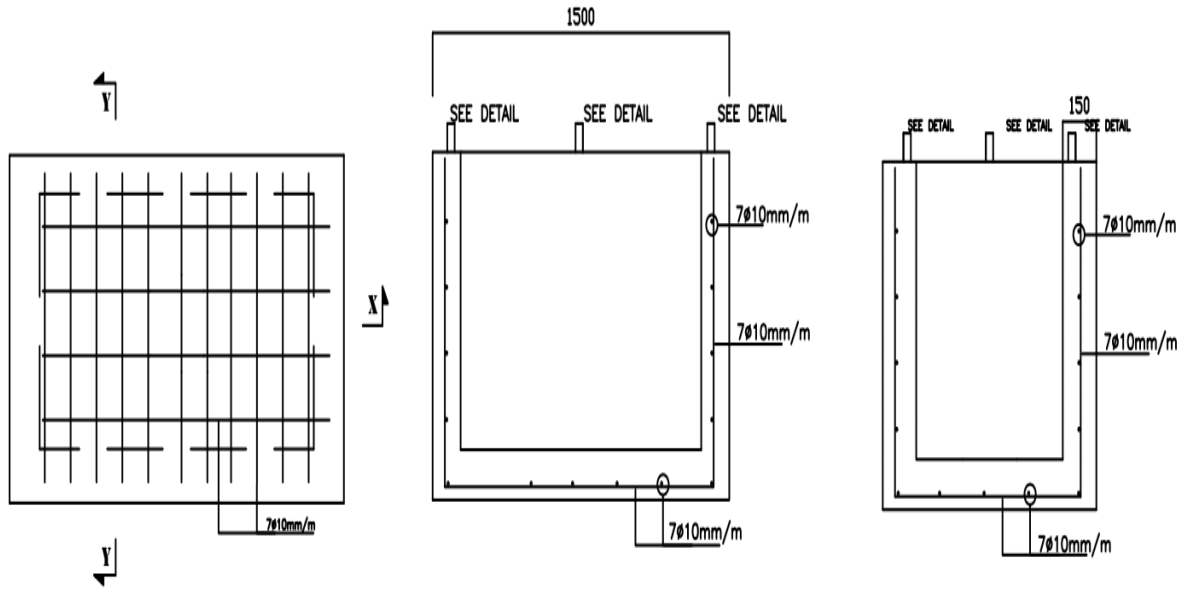

PLAN

SECTION X-X

SECTION Y-Y

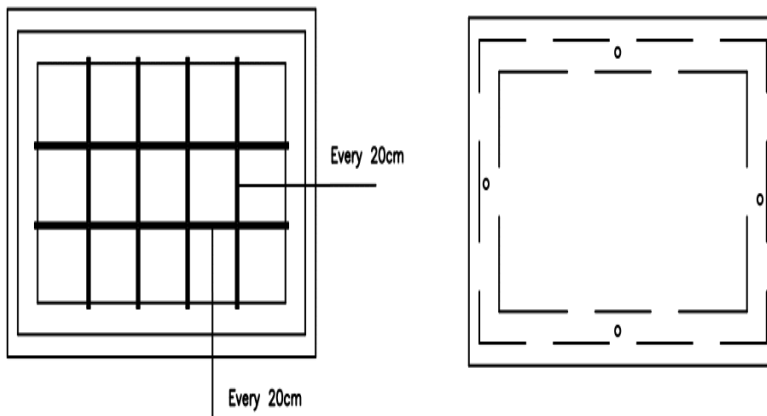

MESH

DRILLING TEMPLATE FOR COVER FRAME

# MANHOLE WITH METALLIC COVER SPECIFICATIONS (part3) ...Cont'd

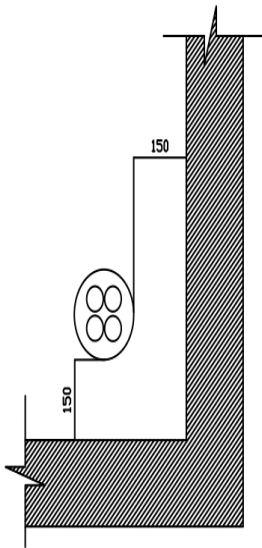

Duct Formation

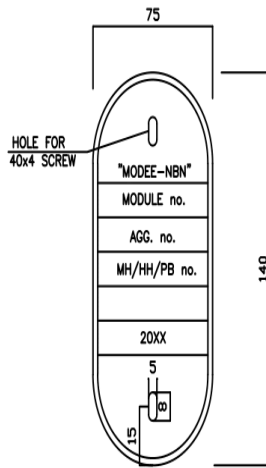

ALUMINIUM MARKER PLATE  
(1.5mm THICKNESS)

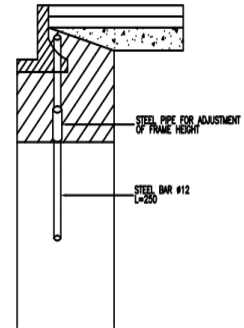

COVER FRAME ADJUSTMENT DETAIL

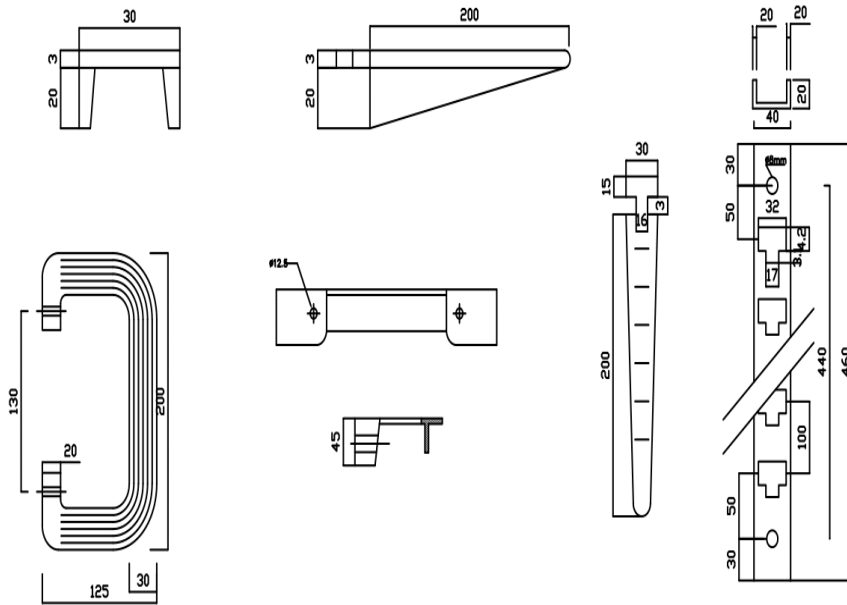

DETAIL OF STEP

CABLE BRACKET SUPPORT DETAIL

DETAIL OF MIDDLE SUPPORT FOR MANHOLES WITH METALLIC COVER (PART1)

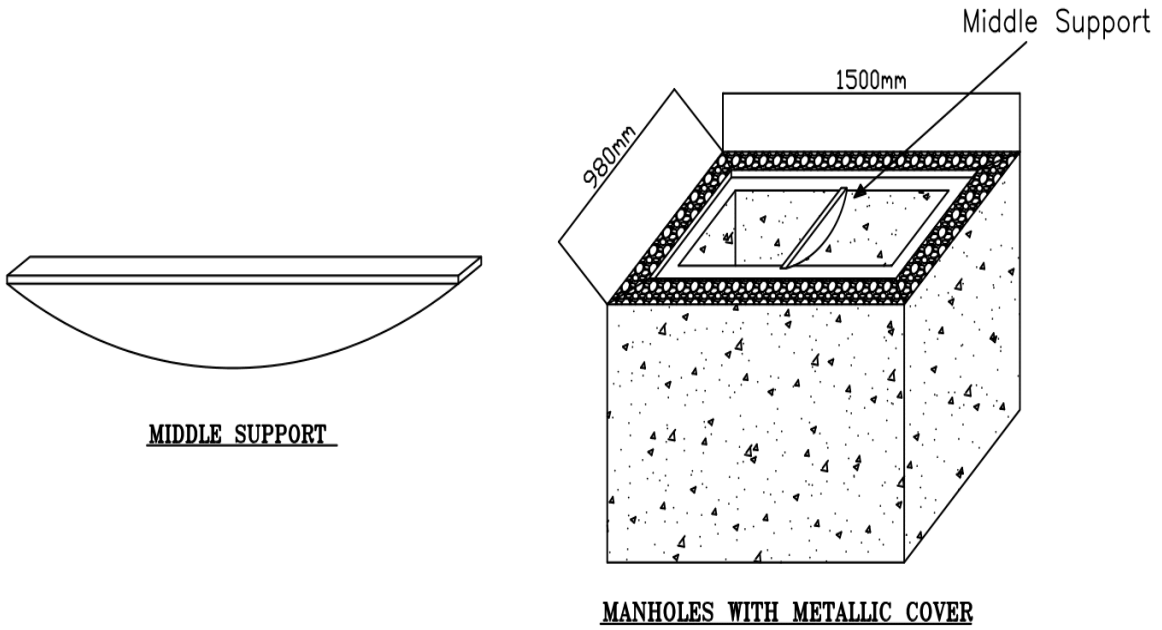

DETAIL OF MIDDLE SUPPORT FOR MANHOLES WITH METALLIC COVER (PART2)...Cont'd

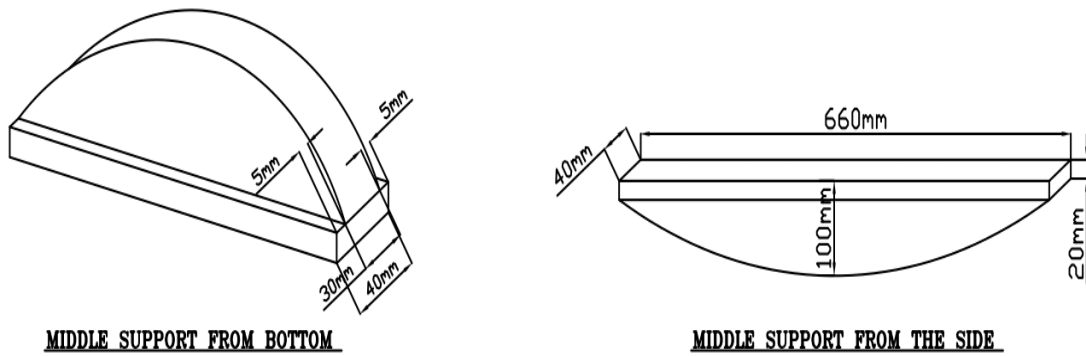

❖ **Manholes In non-Urban areas**

The manholes (100cm(L)\* 100cm(W)\* 100cm(D) as internal dimensions with a base and walls of 20 cm thickness, with a fair-face surface finish made from reinforced concrete with minimum cube crushing strength of 250 kg/cm<sup>2</sup> and 7Ø10 mm/m steel bars in both directions for walls, base and cover. The manholes shall be equipped with terminators, galvanized, step, cable support and brackets, marker plates, frame, and complete hardware package.

The concrete cover, shall be made from reinforced concrete with 10cm thickness. With a label stating "MODEE-NBN" shall be applied and fixed to the cover.

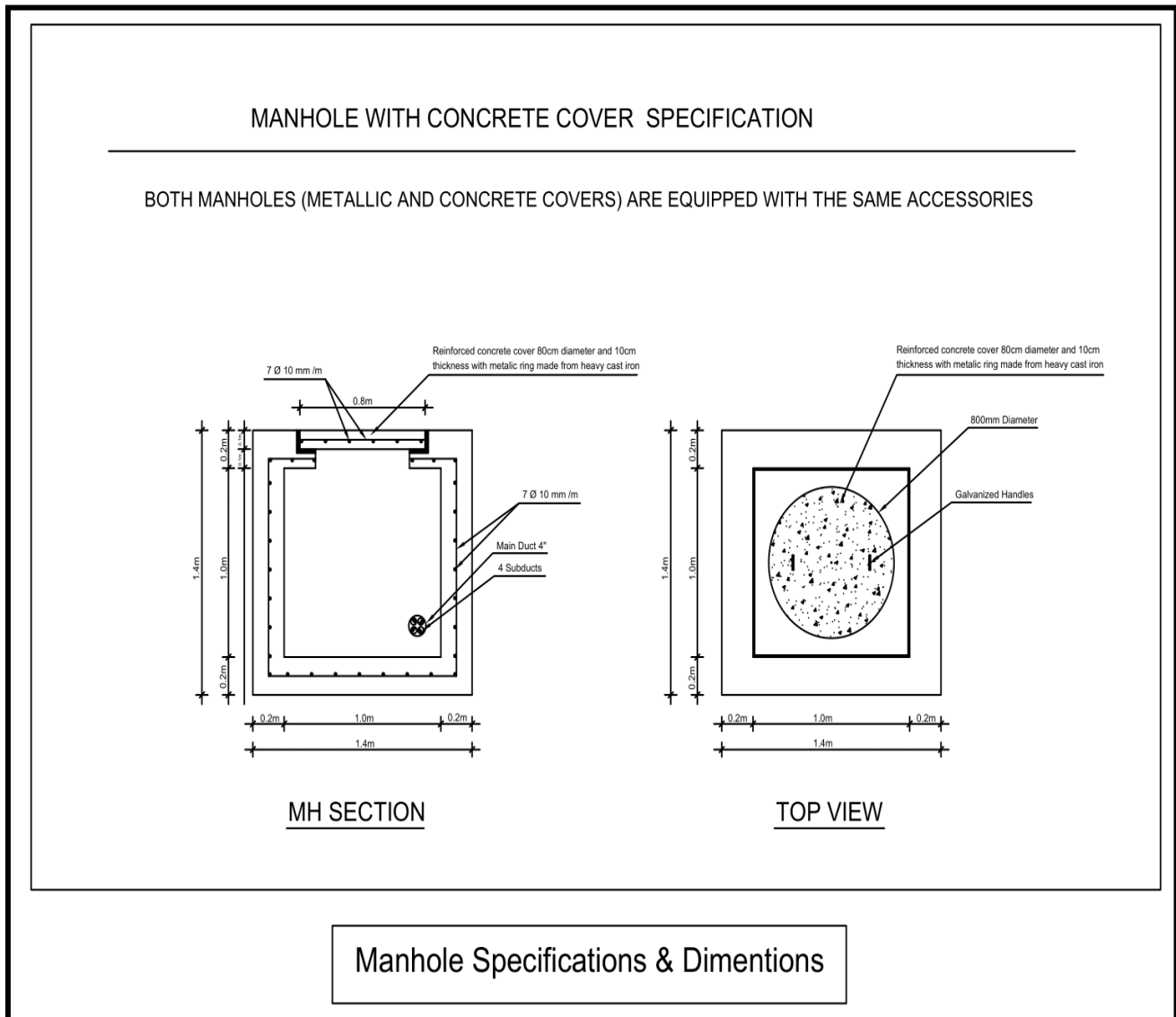

### ❖ Ring Manholes:

- **Ring Manholes (90cm diameter & 90cm depth):**

The manholes (with diameter 90cm & depth 90cm) as minimum internal dimensions with a base and Wall of 10 cm thickness, with a refined surface made from concrete with minimum cube crushing strength of 250 kg/cm<sup>2</sup>. The manholes shall be equipped with terminators, galvanized, step, cable support and brackets, marker plates, frame and complete hardware package. The Manhole's cover shall be of the heavy duty cast iron type.

The cover shall be Metallic and Magnetic with a label stating "MODEE-NBN the cover shall be lockable. And bears 40 ton.

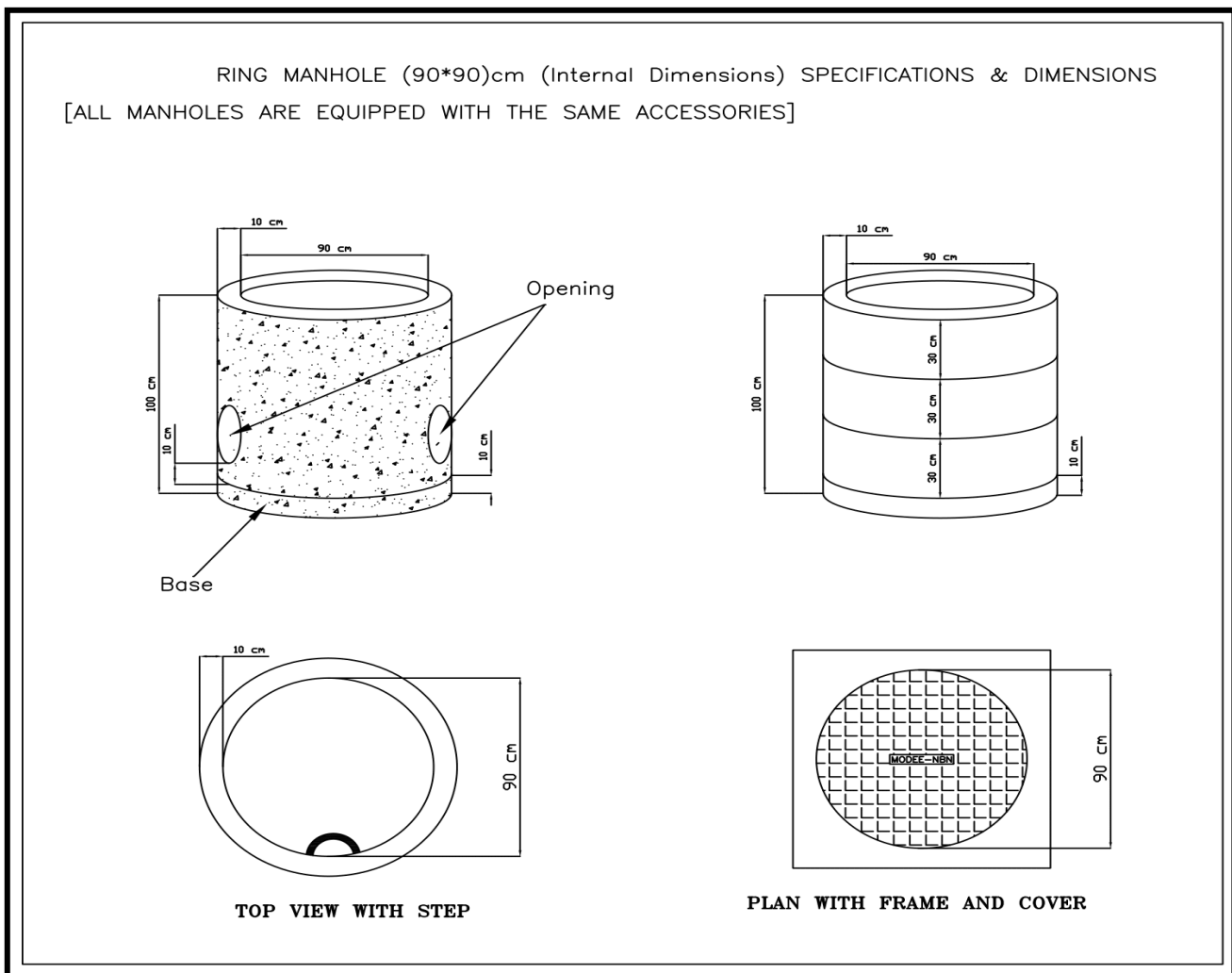

- **Ring Manholes (90cm diameter & 60cm depth):**

The manholes (with diameter 90cm & depth 60cm) as minimum internal dimensions with a base and Wall of 10 cm thickness, with a refined surface made from concrete with minimum cube crushing strength of 250 kg/cm<sup>2</sup>. The manholes shall be equipped with terminators, galvanized, step, cable support and brackets,



marker plates, frame and complete hardware package. The Manhole's cover shall be of the heavy duty cast iron type.

The cover shall be Metallic and Magnetic with a label stating "MODEE-NBN the cover shall be lockable. And bears 40 ton.

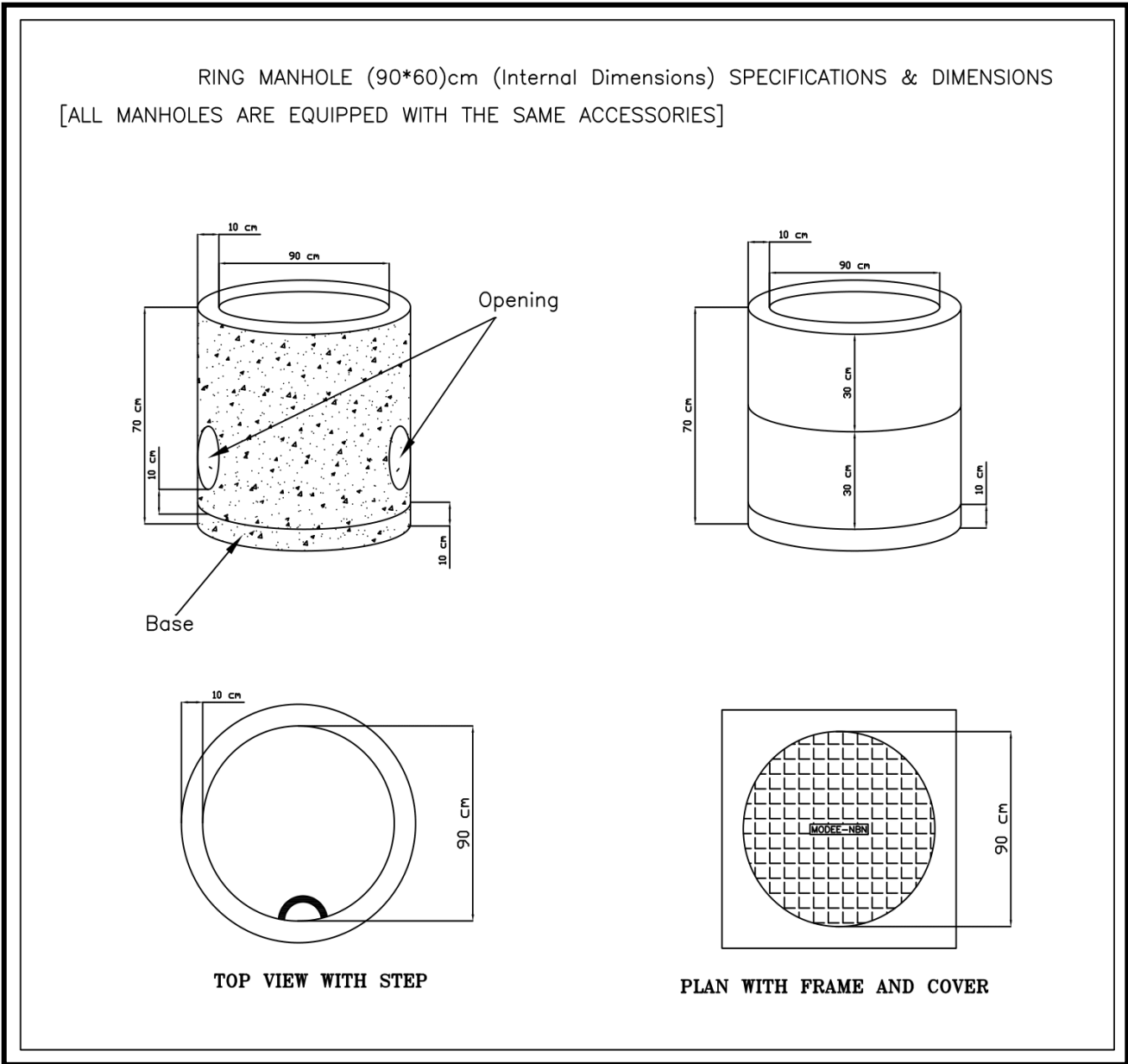

❖ **Handholes with Magnetic Metallic Cover**

The handhole (91.5\*46\*82 cm) as minimum internal dimensions with a base of 15 cm thickness, with a refined surface made from reinforced concrete with minimum cube crushing strength of 250 kg/cm<sup>2</sup>. The handhole shall be equipped with terminators, galvanized, cable support and bracket, marker plate, frame, steel mesh and complete hardware package. The cover shall be of the heavy type.

The cover shall be Metallic and Magnetic with a label stating “MODEE-NBN the cover shall be lockable.

And bears 40 ton

### HANDHOLE WITH METALLIC COVER SPECIFICATION (PART1)

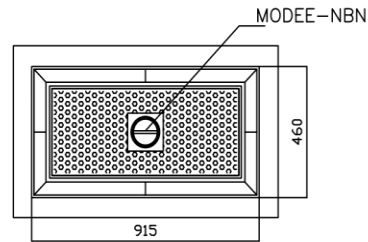
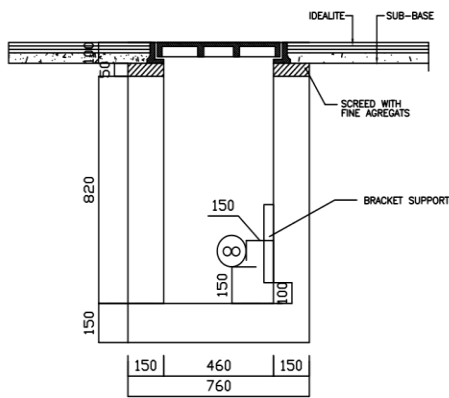
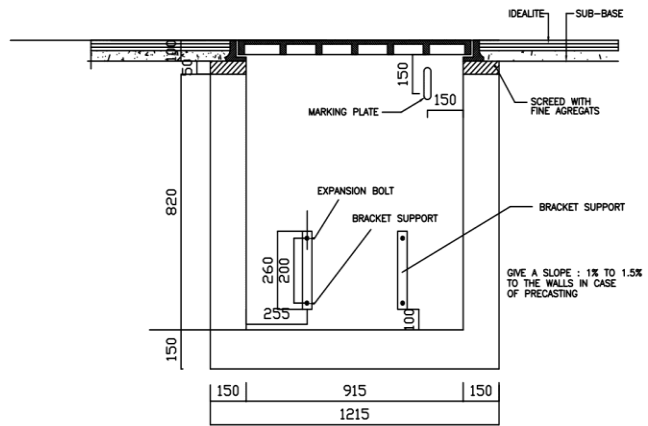
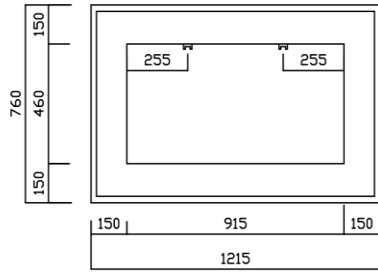

SECTION Y-Y

PLAN OF FRAME AND COVER

# HANDHOLE WITH METALLIC COVER SPECIFICATION (PART2) ....Cont'd

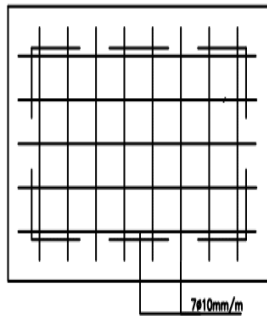

**BOTTOM SLAB  
REINFORCEMENT**

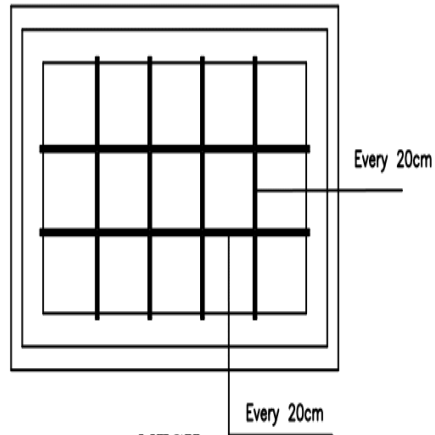

**MESH**

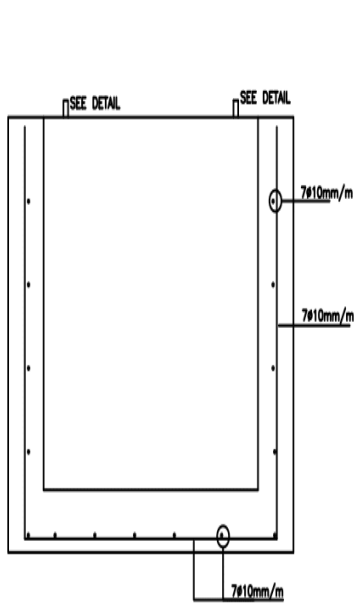

**SECTION X-X**

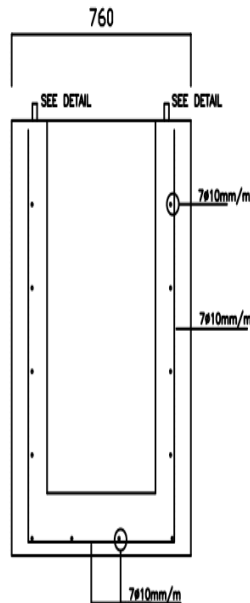

**SECTION Y-Y**

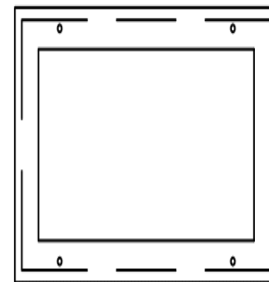

**DRILLING TEMPLATE FOR COVER FRAME**

# HANDHOLE WITH METALLIC COVER SPECIFICATION (PART3) .....Cont'd

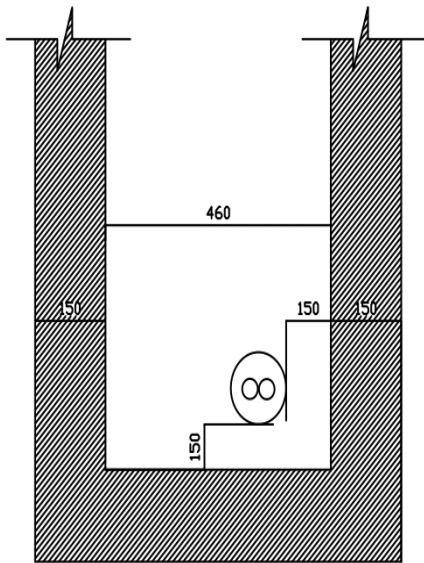

**DUCT FORMATION**

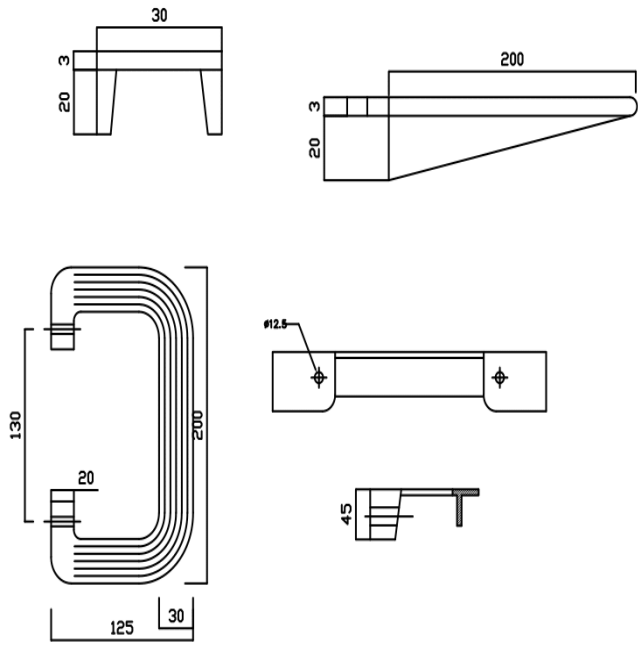

**DETAIL OF STEP**

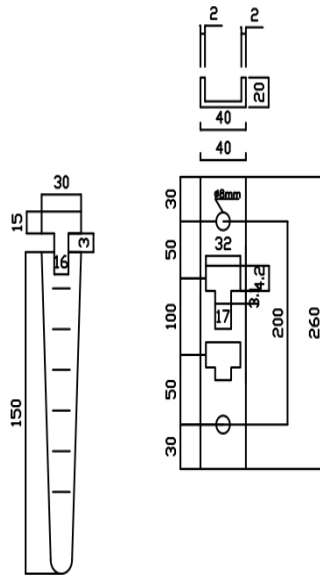

**CABLE BRACKET SUPPORT DETAIL**

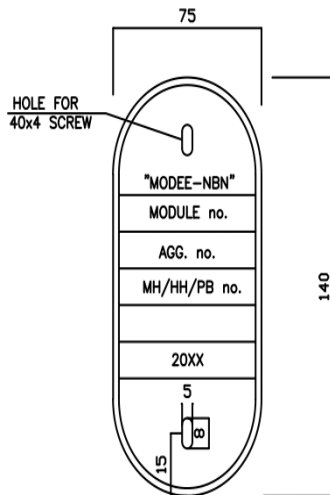

**ALUMINIUM MARKER PLATE  
(1.5mm THICKNESS)**

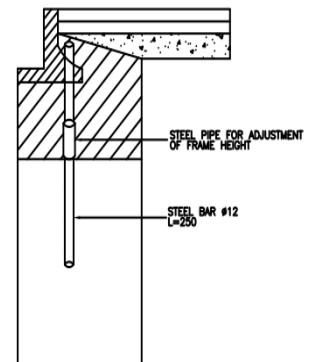

**COVER FRAME ADJUSTMENT DETAIL**

❖ **Ring Handholes:**

- **Ring Handholes (60cm diameter & 90cm depth):**

The Handholes (with diameter 60cm & depth 90cm) as minimum internal dimensions with a base and Wall of 10 cm thickness, with a refined surface made from concrete with minimum cube crushing strength of 250 kg/cm<sup>2</sup>. The Handholes shall be equipped with terminators, galvanized, step, cable support and brackets, marker plates, frame and complete hardware package. The Handholes cover shall be of the heavy duty cast iron type.

The cover shall be Metallic and Magnetic with a label stating “MODEE-NBN the cover shall be lockable. And bears 40 ton

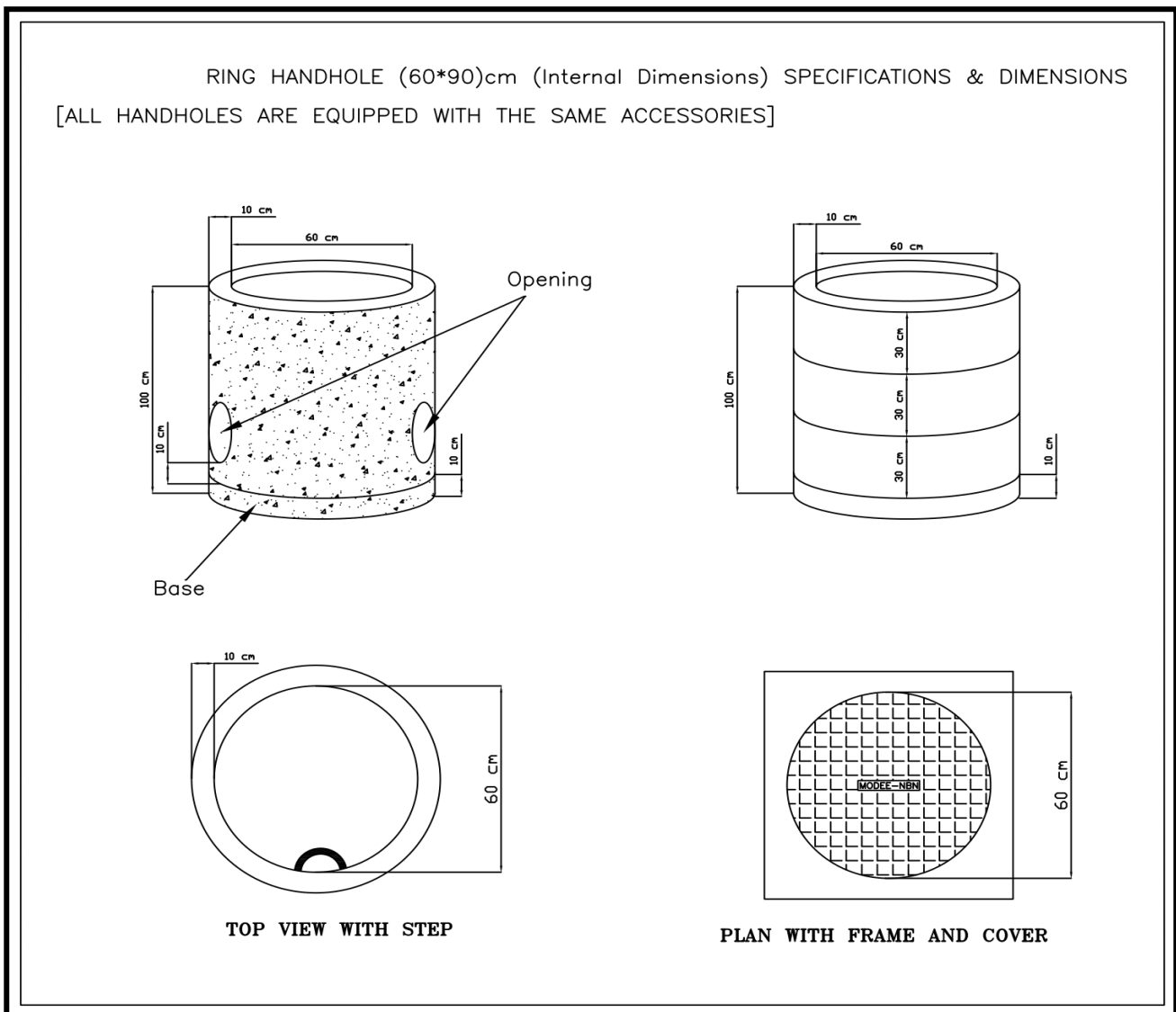

- **Ring Handholes (60cm diameter & 60cm depth):**

The Handholes (with diameter 60cm & depth 60cm) as minimum internal dimensions with a base and Wall of 10 cm thickness, with a refined surface made from concrete with minimum cube crushing strength of 250 kg/cm<sup>2</sup>. The Handholes shall be equipped with terminators, galvanized, step, cable support and brackets, marker plates, frame and complete hardware package. The Handholes cover shall be of the heavy duty cast iron type.

The cover shall be Metallic and Magnetic with a label stating “MODEE-NBN the cover shall be lockable. And bears 40 ton.

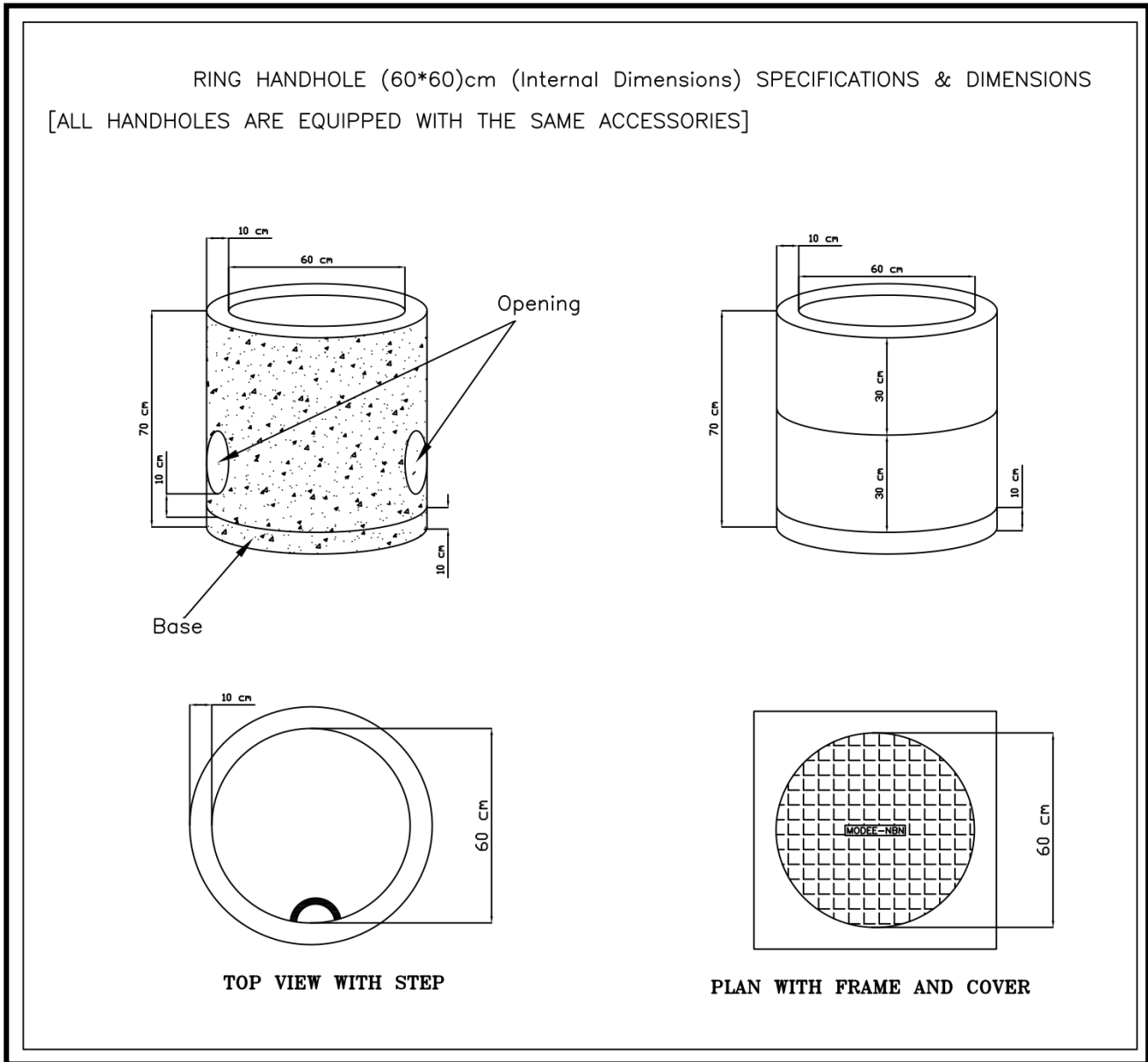

❖ **Pull Boxes**

The pull boxes (50\*25\*48.5 cm) as minimum internal dimensions with a base of 10 cm thickness, with a refined surface made from reinforced concrete with minimum cube crushing strength of 250 kg/cm<sup>2</sup>. The

cover shall be of reinforced concrete type. The pull boxes include: the cover, a marker plat (fixed on the entity's wall near the Pull Box), and finishing.

The cover shall be made of reinforced concrete with minimum cube crushing strength of 250 kg/cm<sup>2</sup> (10 cm thickness) with a label stating "MODEE-NBN".

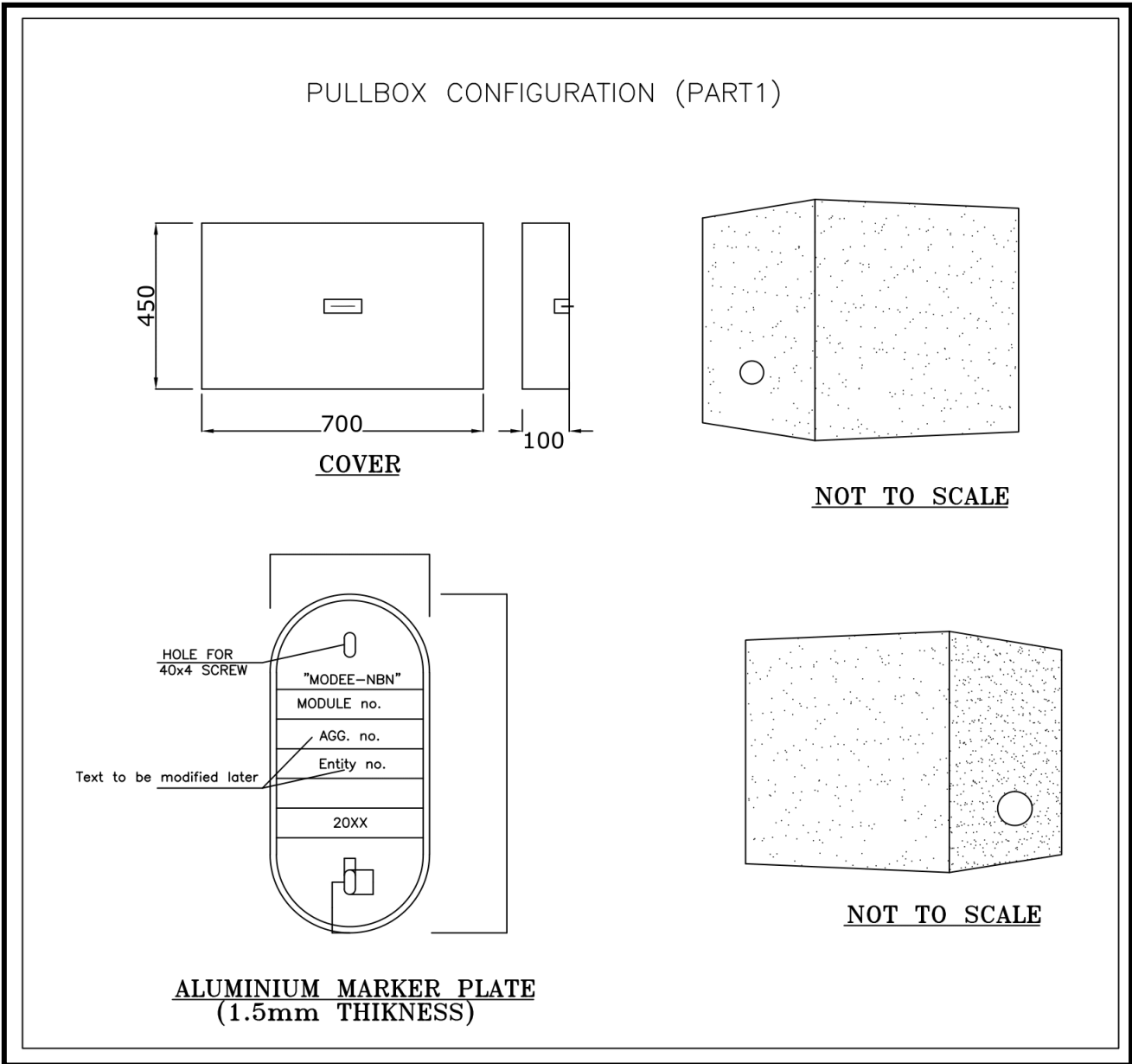

# PULLBOX CONFIGURATION (PART2) ...Cont'd

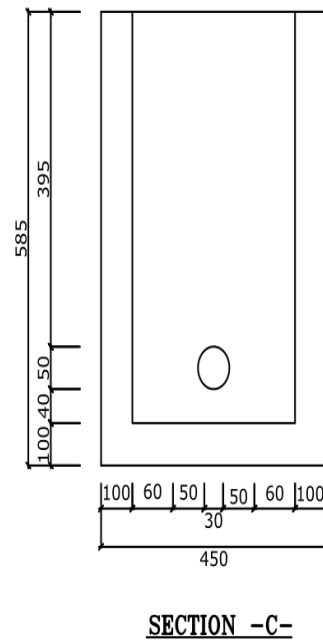
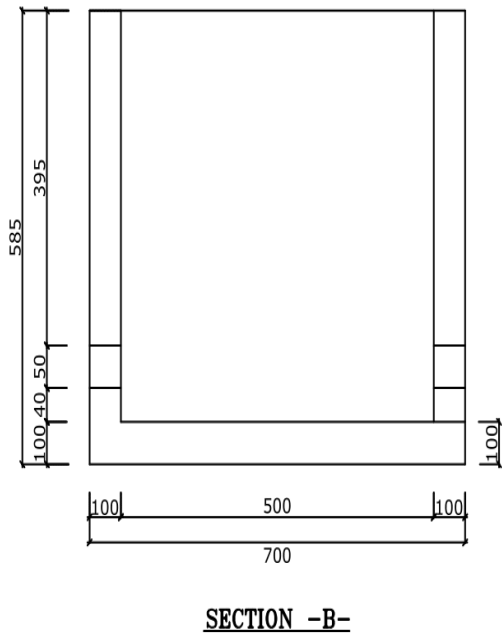
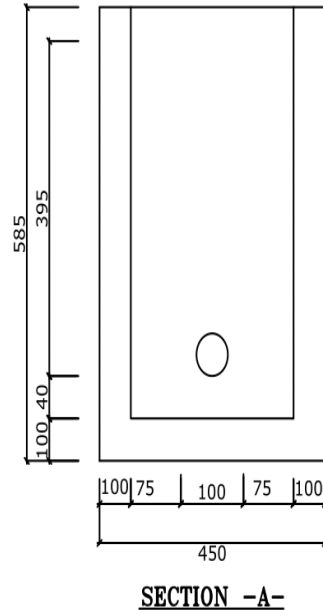
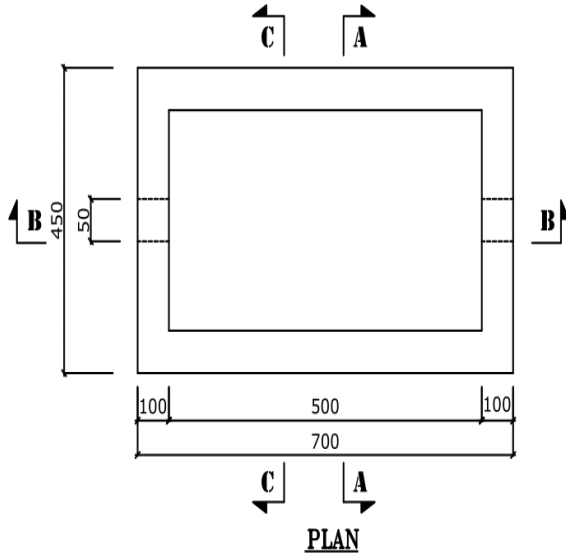



# PULLBOX CONFIGURATION (PART3) ...Cont'd

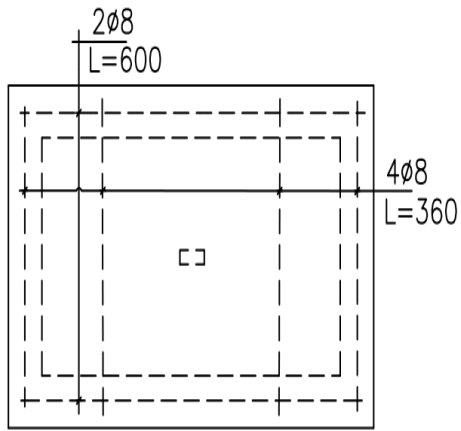

COVER (REINFORCEMENT)

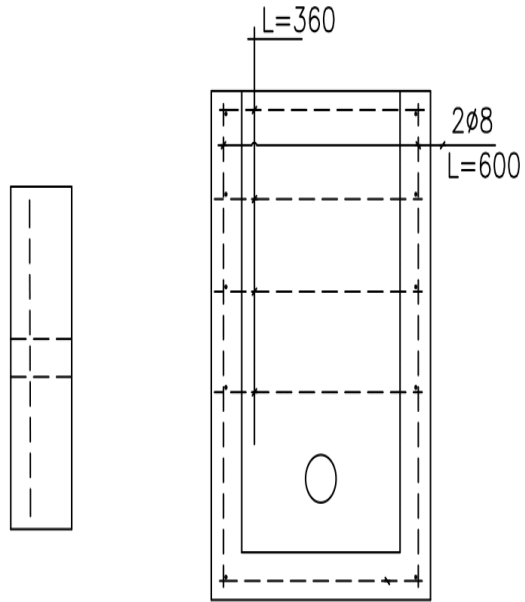

SECTION -A (REINFORCEMENT)

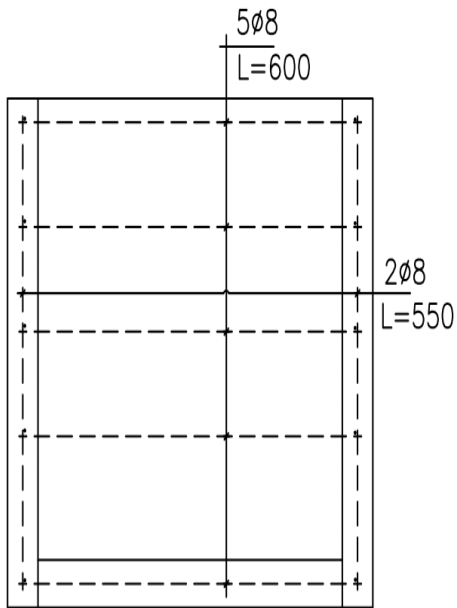

SECTION -B- (REINFORCEMENT)

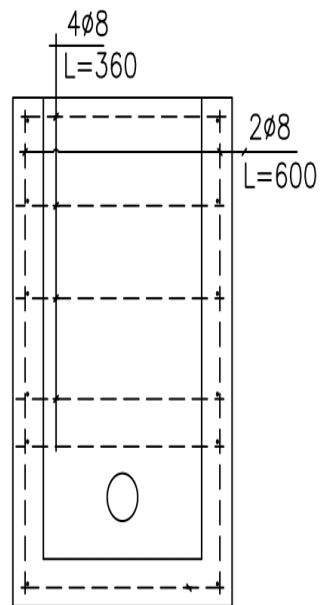

SECTION -C (REINFORCEMENT)

# ANNEX C: TRENCH SPECIFICATIONS

The trench shall be excavated and backfilled in accordance with the drawing below and the descriptions as provided in the bill of quantities.

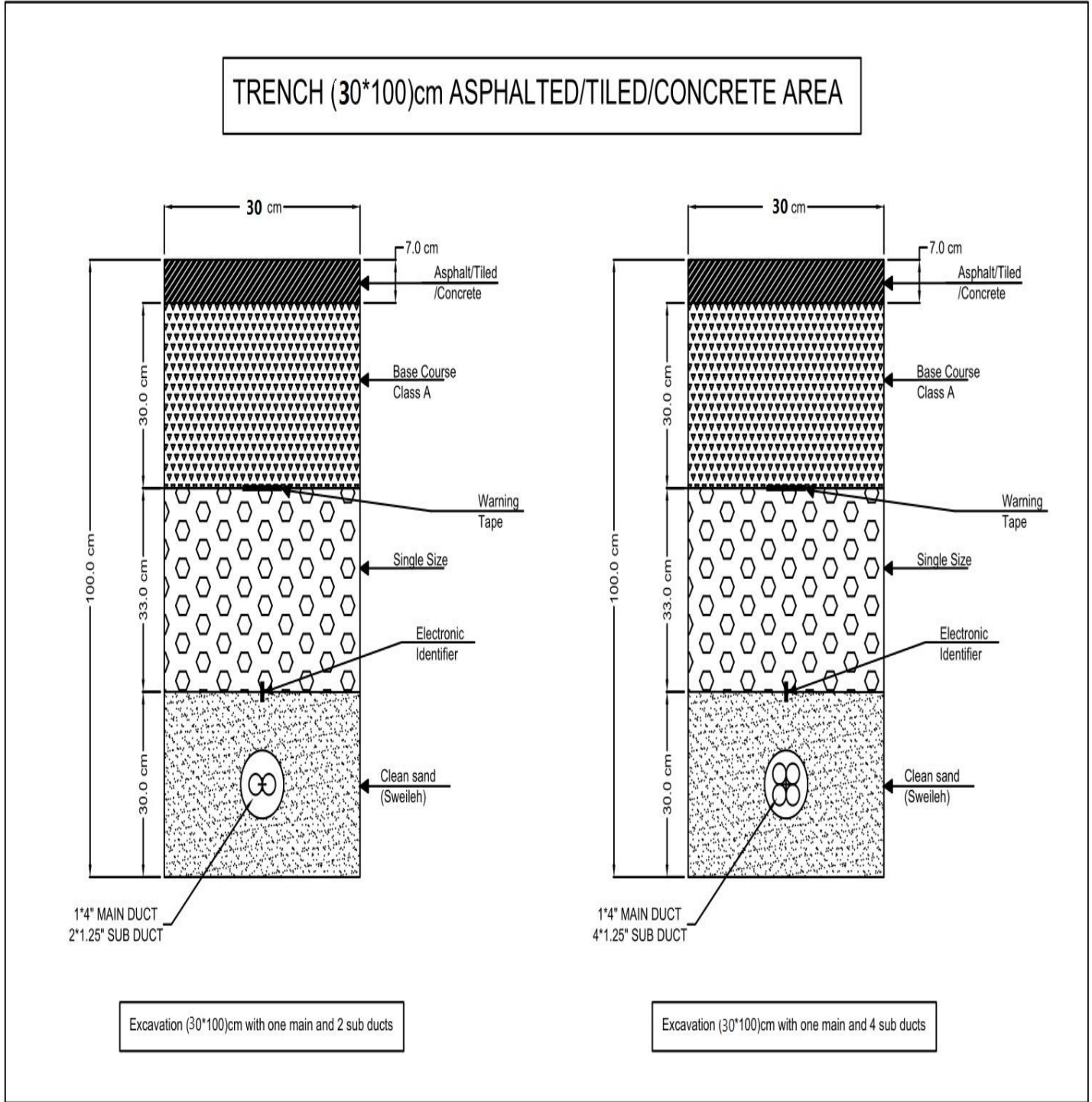

**TRENCH (30\*100) cm NON - ASPHALTED/TILED/CONCRETE AREA**

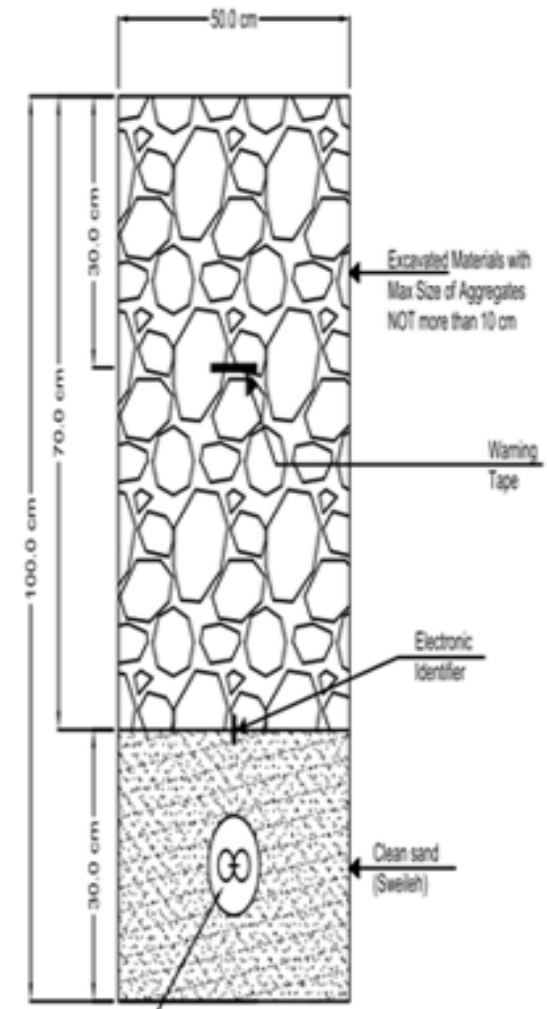

1" MAIN DUCT  
2" SUB DUCT

**Excavation (30\*100) cm with one main and 2 sub ducts**

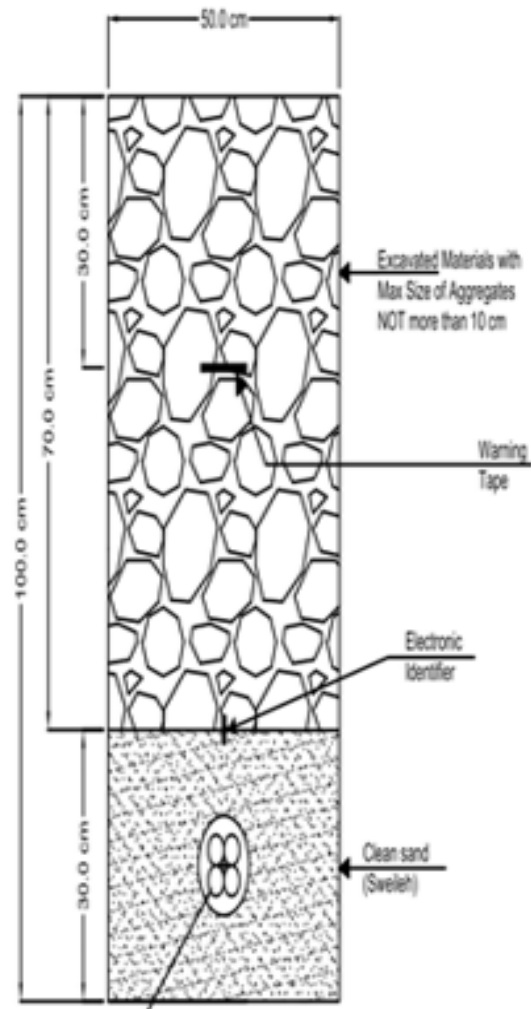

1" MAIN DUCT  
4" SUB DUCT

**Excavation (30\*100) cm with one main and 4 sub ducts**

(15\*50)cm ASPHALTED/TILED AREA (WITH FLOWABLE CONCRETE)

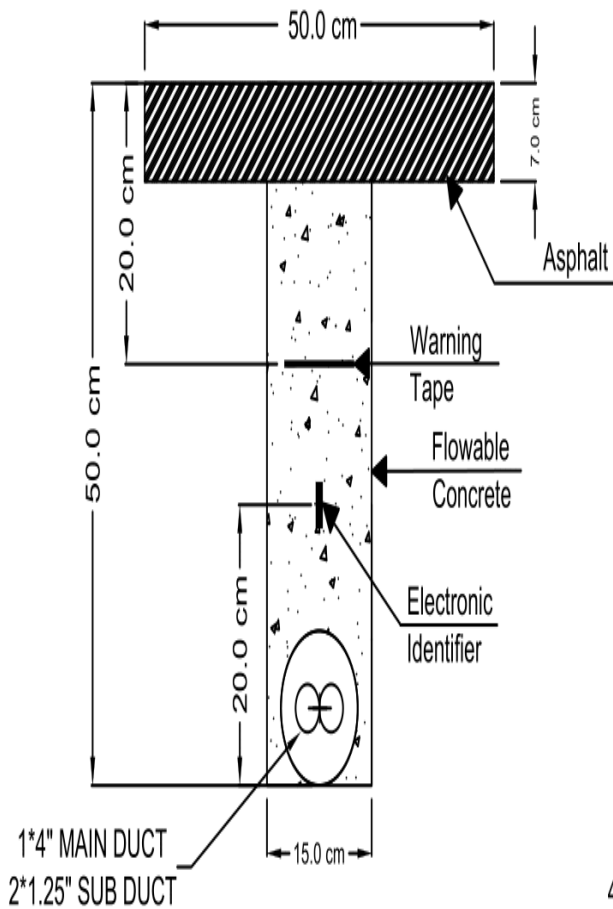

Micro Trench (15\*50)cm with one main and 2 sub ducts

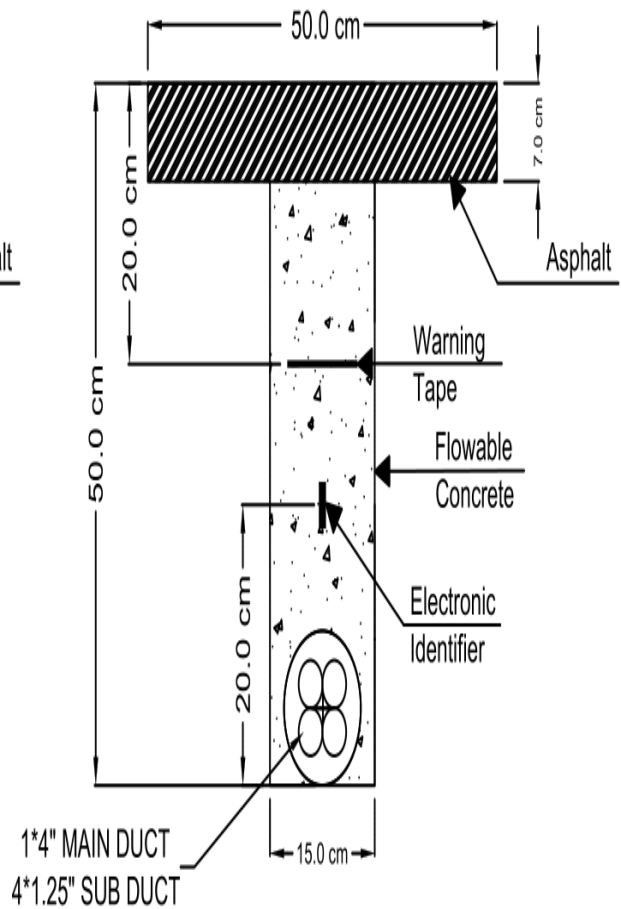

Micro Trench (15\*50)cm with one main and 4 sub ducts

(15\*50)cm ASPHALTED/TILED AREA (WITH CONCRETE 200kg/cm<sup>2</sup> Or 250kg/cm<sup>2</sup>)

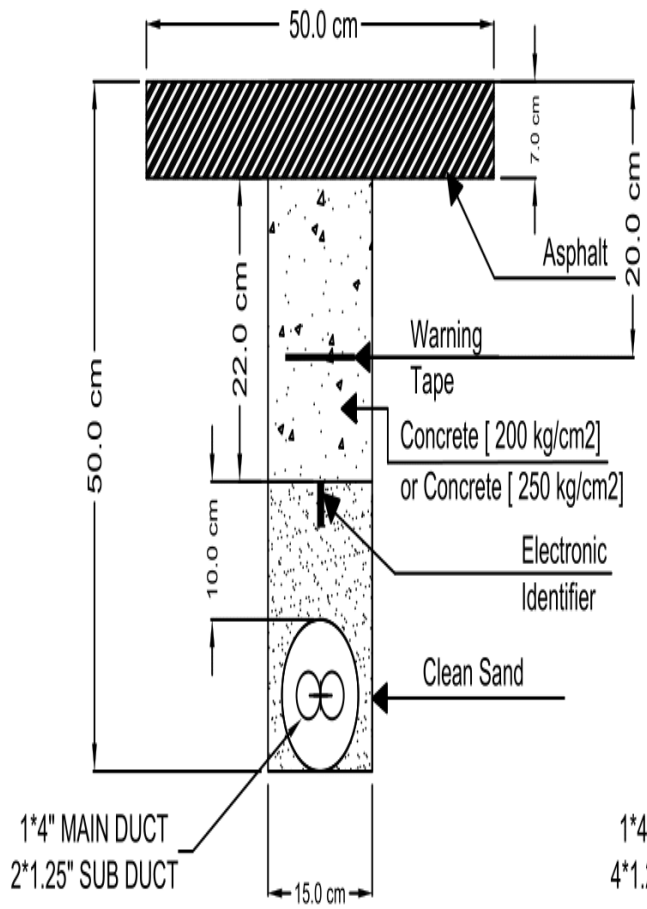

Micro Trench (15\*50)cm with one main and 2 sub ducts

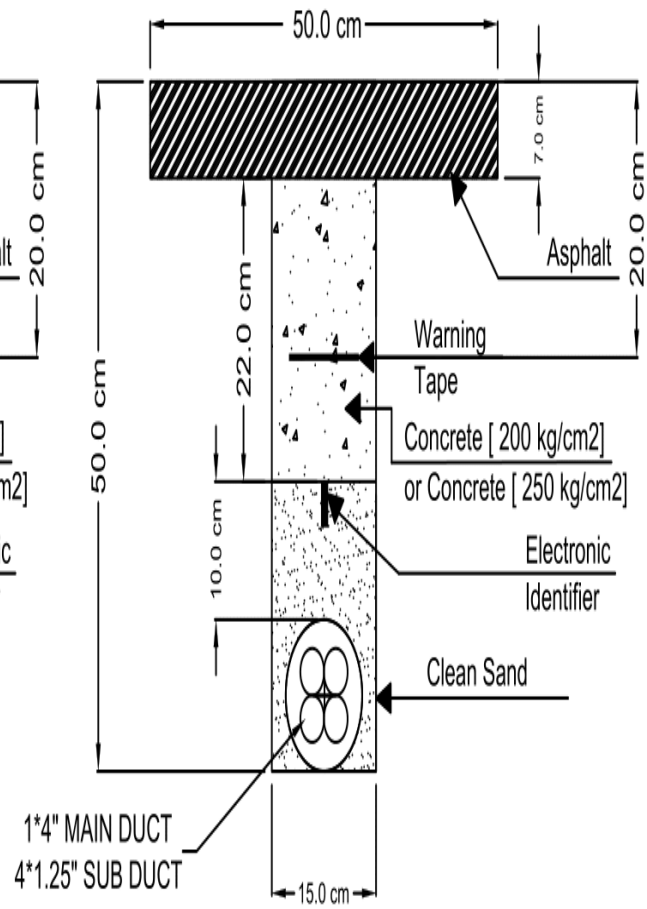

Micro Trench (15\*50)cm with one main and 4 sub ducts

(15\*80)cm ASPHALTED/TILED AREA  
(WITH CONCRETE 200kg/cm2 Or 250kg/cm2)

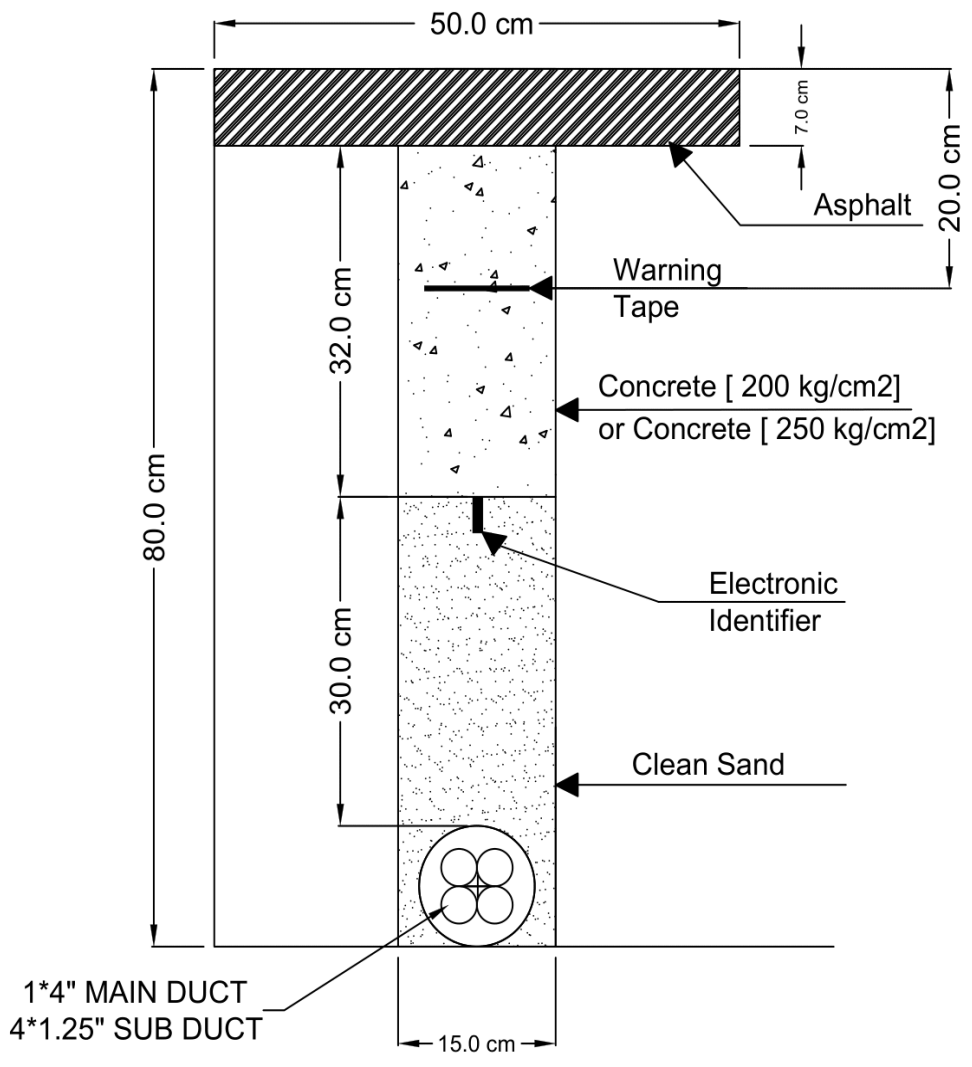

Micro Trench (15\*80)cm with one main and 4 sub ducts

# ANNEX D: ROUTE CROSSING

The route crossing shall be implemented in accordance with the drawings below and the descriptions as provided in the specification.

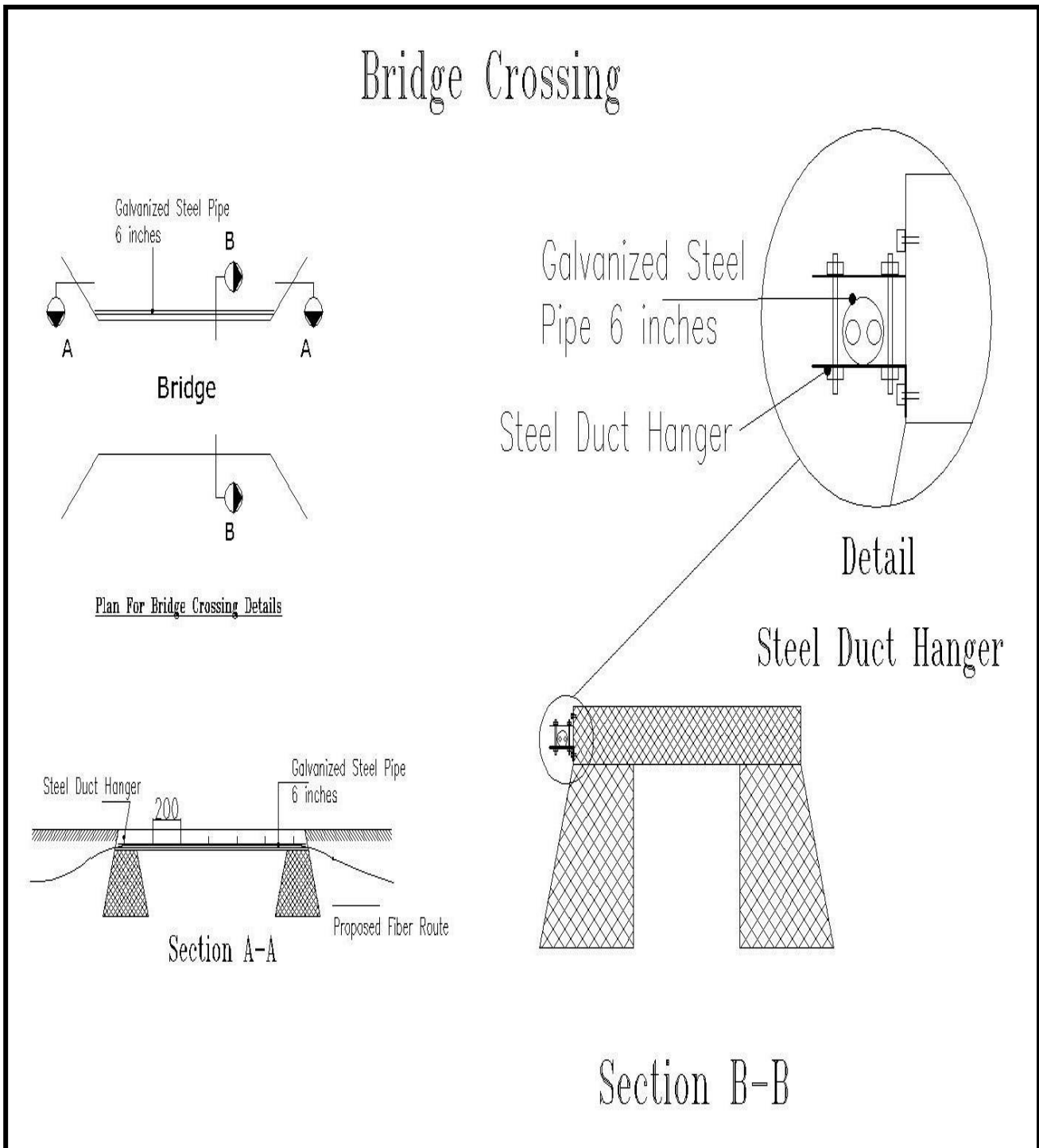

# Railway Crossing

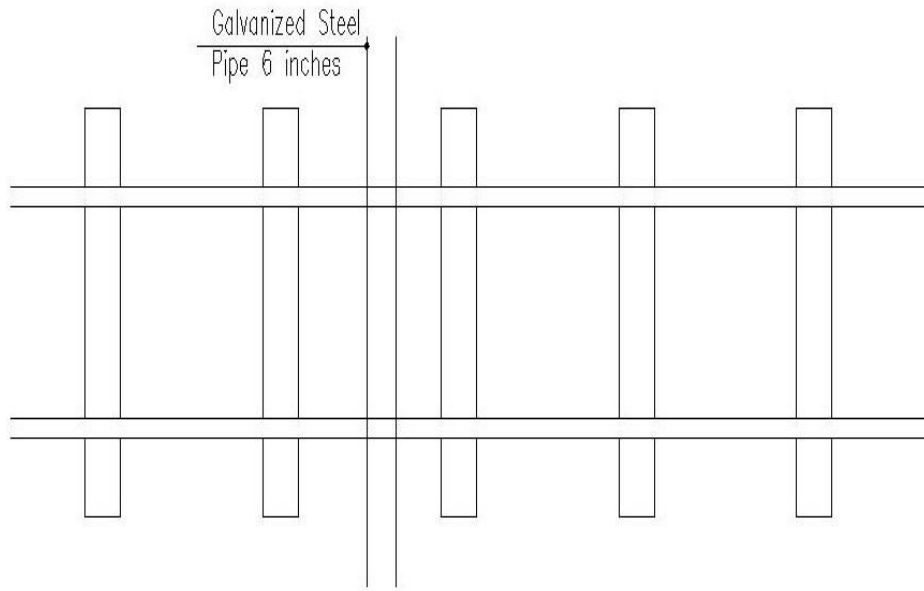

Railway Crossing Top View

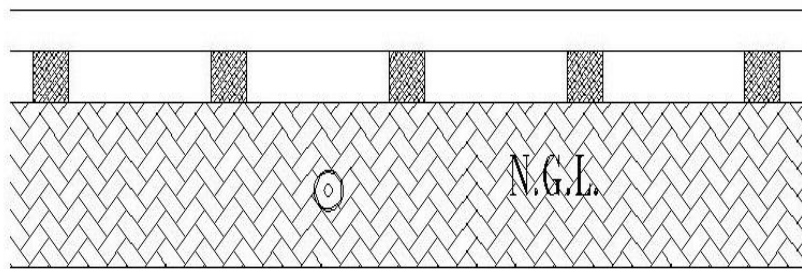

Railway Crossing Side View



**ANNEX E-1: WARNING TAPE:**

**إِتْتِيَه !**

**كوابل ألياف ضوئية**

**(CAUTION ! FIBER OPTIC CABLES)**

**وزارة الإقتصاد الرقمي والريادة**

**MINISTRY OF DEE**

**إِتصل بالمهندس (0800-22045) CALL ENGINEER**

**يمكن الإتصال من أي خط أرضي أو خلوي**

## ANNEX E-2: ELECTRONIC IDENTIFIERS:

Electronic Identifiers shall be installed over proposed underground networks being Water and Waste Water Utilities, and Telecommunication Utilities according to the following specs:

### Specifications:

- The design and construction of the Electronic Identifier shall be rugged, reliable, and durable.
- The cross sectional area be small in order to fit in tight places.
- The following is the required specifications:

Utility	Telecommunication
<b>Color</b>	<b>Orange</b>
<b>Frequency</b>	<b>101.4 KHZ</b>
<b>Accuracy</b>	<b>± 1 %</b>
<b>Depth Range</b>	<b>60 – 150 cm</b>
<b>Operating Temp. ºC</b>	<b>-40 to +70</b>
<b>Storage Temp. ºC</b>	<b>-40 to +85</b>
<b>RLC Circuit</b>	<b>Core of the inductor should be a ferrite core</b>
<b>Housing</b>	<b>Rugged, with a water proof insulating material to protect the RLC circuit in case the outer casing is broken</b>
<b>Life Expectancy</b>	<b>45 years min.</b>
<b>Field Trials</b>	<b>Required, and cannot be conducted during the execution of the project. Any product to be suggested for use should pass a field trial test where a sample of the product is placed in position for 3 months, and tested for operation on monthly basis.</b>

Samples shall be submitted by the contractor to be approved by the Engineer without any additional costs.

### Installation:

Electronic Identifiers shall be installed in the following both manners:

#### Vertically:

Within the top of the soft backfill layer (bedding), over the utility at a depth not exceeding **90 cm** from the surface of the ground.

#### Horizontally:

**One identifier every 6 meters max.**

**Electronic Identifier Locator shall be provided to the MODEE as part of the project deliverables to be used to verify that all identifiers have been installed properly.**

# **FIBER SPECIFICATIONS:**

## **ANNEX F-1:**

### **TECHNICAL SPECIFICATIONS OF OPTICAL FIBER CABLE**

- **DUCT TYPE (G.652 D).**
- **LOOSE TUBES.**
- **SINGLE OUTER JACKET.**
- **BLACK OUTER SHEATH.**

#### 1. General Considerations

The cable shall be designed for applications inside protective UPVC sub-duct of 32 mm diameter.

This specification describes the cable design, properties of the fibers and the cable, the testing and the quality assurance during manufacturing, the final acceptance tests and the packaging.

Single mode optical fiber cables which are optimized for use in both wave lengths windows of 1310 nm and 1550 nm are required. The optical fiber cables shall meet the requirements stated in ITU-T Rec. G.652 D.

The cable shall be new, unused and of current design and manufacture.

The identification label printed on cable every one meter and shall contain the text “**MODEE-NBN**”.

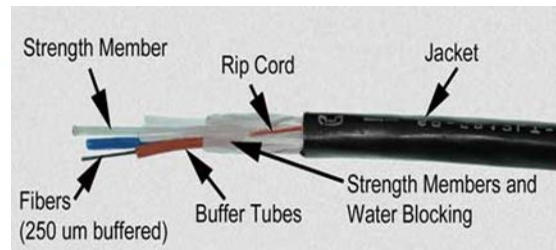
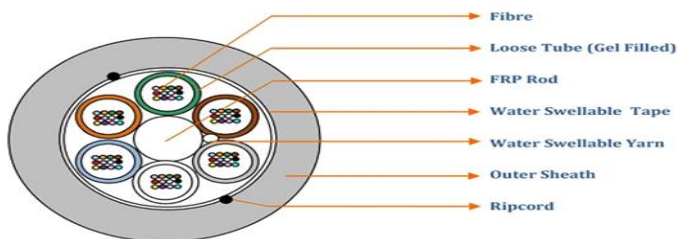

#### 2. Standards

**The specification refers to the following standards:**

- IEC60793-1: Optical Fibers - Part 1: Generic Specification.
- IEC60793-2: Optical Fibers - Part 2: Product Specifications.
- IEC60794-1: Optical Fiber Cables - Part 1: Generic Specification.
- IEC60794-4: Optical Fiber Cables - Part 4: Sectional Specifications for OCEPL.
- EIA/TIA 598: Color Coding of Fiber Optic Cables.
- EIA/TIA 492-CAAB.

### **Fiber Characteristics**

#### **3.1. General Fiber Specifications**

The fibers shall meet all requirements according to IEC 60793-2 Category B1.

All optical fibers shall be sufficiently free of surface imperfections and inclusions to meet the optical, mechanical, and environmental requirements of this specification. **Factory made optical fiber splices are not allowed.**

Each optical fiber shall consist of a SiO<sub>2</sub> core doped with GeO<sub>2</sub> and a fused SiO<sub>2</sub> cladding (matched clad) giving a fiber with a step profile of the refractive index.

The coating shall be easily strippable by means of a mechanical stripping tool without damaging the fibers. No chemicals shall be required.

The fibers shall be completely phosphorus free.

#### **3.2. Optical and Mechanical Characteristics of Standard Single Mode Fibers**

Single-mode Low Water Peak fiber shall be utilized in these optical fiber cables and shall meet the ITU recommendation G.652 D, "Characteristics of a Single-Mode Optical Fiber Cable".

This requirement defines standard single-mode fibers for use across a broad wavelength range including the extended band (1360 nm - 1460 nm).

**These fibers shall have the specified performance and geometry values except as noted below:**

<b>Mode field diameter (1310 nm):</b>	<b>9.2 μm ± 0.4 μm</b>
<b>Mode field diameter (1550 nm):</b>	<b>10.4 μm ± 0.5 μm</b>
<b>Cladding diameter:</b>	<b>125 μm ± 0.7 μm</b>
<b>Mode field concentricity error:</b>	<b>≤ 0.5 μm</b>
<b>Cladding non circularity:</b>	<b>≤ 0.8 %</b>
<b>Refractive index profile:</b>	<b>step</b>
<b>Design:</b>	<b>matched cladding</b>
<b>Effective group index of refraction N<sub>eff</sub> (at 1310nm): manufacturer).</b>	<b>1.4677 (to be provided by manufacturer).</b>
<b>Effective group index of refraction N<sub>eff</sub> (at 1550nm): manufacturer).</b>	<b>1.4682 (to be provided by manufacturer).</b>

<b>Cut off wavelength of cabled fiber:</b>	<b><math>\leq 1260</math> nm</b>
<b>Attenuation at 1310 nm:</b>	<b><math>\leq 0.35</math> dB/km</b>
<b>Attenuation at 1383 nm:</b>	<b><math>\leq 0.35</math> dB/km</b>
<b>Attenuation at 1550 nm:</b>	<b><math>\leq 0.22</math> dB/km</b>
<b>Attenuation at 1625 nm:</b>	<b><math>\leq 0.24</math> dB/km</b>

The attenuation measurements shall be made after finally winding the cable on its shipping drum. Cable ends shall then be hermetically sealed.

- Zero-dispersion over the range **1300 - 1324 nm**.
- Zero dispersion slop (S0): $\leq 0.089$  PS/ (nm<sup>2</sup>.km).
- **Maximum dispersion at the wavelength 1550 nm:** shall not exceed **18 ps/nm.km** or as pair ITU-T recommendation Rec. G.652 D.
- **Polarization Mode Dispersion (PMD):** should also be verified to guarantee future extreme high bit-rate operation (> 10 Gb/s).
- **The PMD at 1550 nm.:** should have been **less than** 0.1 ps/sqrt (km)

### 3.3. Core Material

The core of the optical fiber, with a higher refractive index compared to the cladding, is made of SiO<sub>2</sub> (Silicon dioxide) doped with GeO<sub>2</sub> (Germanium dioxide).

### 3.4. Cladding Material

The cladding of the optical fiber is made of SiO<sub>2</sub> (Silicon dioxide).

### 3.5. Type of Primary Coating

The primary coating is made of an UV-curable acrylate. It is applied in two layers, each of a different Young's modulus. The inner layer is somewhat softer than the outer one. This make-up protects the fiber against micro bending losses and against abrasion.

### 3.6. Dimension of Primary Coating

- The dimension of the primary coating: **245 ± 5 μm**.

### 3.7. Mechanical Characteristics of the Primary Coating

The primary coating is easily strippable by means of a mechanical stripping tool. No chemicals shall be used.

### 3.8. Mechanical Characteristics of Fiber

A non-metallic central core shall be provided which may constitute the strength member designed to withstand all longitudinal stresses or its strength may be supplemented by an additional stress sharing sheath. The core shall be of a non-hygroscopic material.

- Proof test stress:
  - 8 N for 1 second; strain: 1 %.
- Each optical fiber shall be proof tested by the fiber manufacturer :
  - A minimum of 100 kpsi (0.7 Gpa).

Cable shall be able to contain 24 to 144F Colored fibers. Color coded binders shall be used to segregate the fibers into color coded groups. To the extent possible, colored fibers shall be segregated in groups of 12. And each buffer tube must contain 12 colored fiber.

<b>Fiber Color Coding:</b>	fiber-# 1 : Blue	fiber-# 7 : Red
	fiber-# 2 : Orange	fiber-# 8 : Black
	fiber-# 3 : Green	fiber-# 9 : Yellow
	fiber-# 4 : Brown	fiber-# 10 : Violet
	fiber-# 5 : Slate	fiber-# 11 : Pink
	fiber-# 6 : White	fiber-# 12 : Turquoise

- The binders of the fibers bundles shall be distinguishable by means of color coding in accordance with TIA/EIA-598-B, "Optical Fiber Cable Color Coding".

The central buffer tube shall be filled with a non-hygroscopic, non-nutritive to fungus, electrically non-conductive, homogenous gel in order to prevent water penetration and migration. The gel shall be free from dirt and foreign matter. The gel shall be readily removable with conventional nontoxic solvents.

- The central metal tube shall be surrounded by a high density polyethylene (HDPE) jacket which shall have a bright color (e.g. orange, red, blue). The nominal jacket thickness shall be minimal 1 mm. The jacket shall not promote the growth of fungus.
- The diameter of loose tube: 2.5mm.

#### The outer jacket Specifications:

The jacket shall be continuous, circular, joints free, pinholes free, splits free, blisters free, or other imperfections. The jacket shall have a consistent, uniform thickness; pressure extruded jackets are not acceptable. Thickness of the sheath shall be uniform & shall not be less than 1.5 mm.. The jacket shall be smooth, as is consistent with the best commercial practice. The jacket shall provide the cable

with a tough, flexible, protective coating, able to withstand the stresses expected in normal installation and service.

- Easy to strip.
- A high-density polyethylene (Black HDPE) must make the outer jacket.
- The outer jacket should be black of color.
- Cable Diameter should be not less than 10mm.

- **RIP Cord:**

Two suitable rip cords shall be provided in the cable, which shall be used to open the HDPE sheath of the cable. The rip cords shall be placed diametrically opposite to each other. It shall be capable of consistently slitting the sheath without breaking for a length of 1 meter at the installation temperature. The rip cords (3 ply & twisted) shall be non-wicking type and shall not work as a water carrier.

- **Cable outer jacket shall be marked with:**

- Manufacturer's name, month and year of manufacture, sequential meter markings.
- Telecommunication handset symbol
- "MODEE-NBN" Ministry of Digital Economy and Entrepreneurship.as required by Section 350G of the National Electrical Safety Code® (NESC®),
- Fiber count and fiber type.
- The actual length of the cable shall be within +/- 1 % of the length markings.
- **The print color shall be contrast** with the cable jacket .The letters must be **engraved** on the Cable jackets clearly, not dimmed and the ink must be suitable for cable jacket material. The size of the marking letters shall be approximately 2.5 mm.

If the initial marking fails to meet the specified requirements (i.e., improper text statement, color, legibility, or print interval), the cable may be remarked using a contrasting alternate color. The numbering sequence will differ from the previous numbering sequence, and a tag will be attached to both the outside end of the cable and to the reel to indicate the sequence of remarking.

The maximum pulling tension shall be 1000 N during installation (short term) and 250 N long term installed.

- **Temperature range:**

- Shipping and storage: (-30°C to +70°C).
- Operating temperature: (-30°C to +70°C).
- Installation temperature: (-5°C to +70°C).

4. General Cable Performance Specifications

The cable shall fulfill the following mechanical, thermal and electrical characteristics. If applicable, during and after the tests, the attenuation shall be monitored at the operating wavelength.

#### 4.1. Tensile Performance

- The cable shall be tested in accordance with IEC 60794-1-E1.
- The cable shall be subjected to a load of 1000 N. No fibers shall exhibit a measurable change in attenuation after load removal.
- Load of 2500 N at least.

#### 4.2. Crush Resistance

The cable shall withstand a compressive load of 30 kN/m (300N/cm) - 50 kN/m (500N/cm) for duration of 15 minutes. The load shall be applied uniformly over the length of the compression plate. The cable shall be tested in accordance with IEC 60794-1-E3. No fibers shall exhibit a measurable change in attenuation after load removal.

#### 4.3. Cable Bend

The minimum bending radius of the cable shall be more than 5 times the outer diameter. It shall be tested in accordance with IEC 60794-1-E11. After the test there shall be no change in fiber attenuation greater than the uncertainty of measurement.

- It shall be tested in accordance with IEC 60794-1-E11. After the test, there shall be no change in fiber attenuation greater than the uncertainty of measurement.
- Min. bending radius mm :
  - Durring Installation (Dynamic) 20 x Cable outer diameter.
  - After Installation (Static) 10 x Cable outer diameter.

#### 4.4. Temperature Cycling

- The cable shall be subjected to:
  - Minimum temperature of -30°C.
  - Maximum temperature of +70°C.
- The test shall be performed in accordance with IEC 60794-1-F1. The change in fiber attenuation shall not be greater than the uncertainty of measurement.

#### 4.5. Water Penetration

- A 1 m sample of the cable shall be subjected to a water penetration test according to IEC 60794-1-F5.



- After duration of 24 hours no water shall be detected at the open end of the cable core.

## **5. Testing**

### 5.1. Type Test

The type tests given in Section 6 shall be performed on the fiber optic cable.

### 5.2. Factory Acceptance Test

The cable performance shall be proved by showing detailed test reports of the optical attenuation (if applicable) during and after the test and all relevant test parameters of the type test.

### 5.3. Routine Test

- The optical attenuation coefficient as required in Section 3.2 shall be verified at 1550 nm on all production cable lengths. The test shall be performed according to IEC 60793-1-C1C (Backscattering technique).

## **6. Quality Assurance Provision**

- The manufacturer shall carry out quality inspection and keep a record of the test results to an extent agreed.
- The manufacturer shall also have a trace ability of the materials used, and of the production steps, used in the manufacturing of the cable to an extent agreed.
- The supplier shall provide details of his quality control procedures that shall include the methodical recording of the results of production measurements.
- Test result shall include the following:

1. Cable designation.
2. Number of fibers.
3. Fiber type.
4. Refractive index.
5. Drum no.
6. Length of cable.
7. Data of measurements.
8. Attenuation for every fiber at 1310 nm.

9. Attenuation for every fiber at 1550 nm.
10. Zero-dispersion wavelength for every fiber.
11. Zero-dispersion slope for every fiber.
12. Maximum and minimum value of mode field diameter of fibers in the cable.
13. Maximum and minimum value of cut-off wavelength in the cable.
14. A core-concentricity error of fibers in the cable.
15. Dispersion.
16. The test results shall be attached on the drum.

## **7. Packaging:**

- Cables shall be uniformly wound with no gaps between successive turns.
- Cable ends shall be effectively sealed against physical damage, the ingress of water and loss of jelly filling, opening and re-sealing being possible at least ten times.

Identification of the cable drum shall include the following parameters:

1. Name of manufacturer and year of production.
2. Cable designation and content.
3. Cable ID numbers.
4. Length of cable and start and finish mark.
5. Order no.
6. Any other useful information.

Drum size shall preferably be suitable for cable lengths of **4000 m** as one piece. Longer pieces are preferable.

Tenderers shall state the maximum drummed cable length of each cable type offered and the size and gross weight of loaded drums.

The cables shall be supplied on a wooden drum. Each length of cable shall be wound on a separate drum.

The diameter of the drum barrel shall be large enough to prevent damage to the cable during reeling or unreeling. The diameter of the barrel shall not be smaller than 40 times the outer diameter of the cable.

The drum shall be durable and constructed such as to prevent damage to the cables during shipment and handlings.

Lags or other suitable means of protection shall be applied to the drum to prevent damage to the cables during shipment and storage. Nails and staples used in the construction of the drum must not be placed in a position where they can damage the cables. The drums shall be non-returnable.

Drums with a ramp should be used. For test purposes a length of approx. 4 - 5 m of the inner end shall be accessible.

The cable ends shall be sealed with shrinking caps and fastened tightly. A protective wrap shall be applied over the outer layer of the cable on each reel. The wrap shall be weather resistant and shall not be removed until the cable is installed.

Marking plates, containing following information shall be securely attached to the outer side on each drum flange:

- Type and size of cable.
- Cable length in meters.
- Gross weight in kilograms.
- Reel number.
- Manufacturer's name.
- Year of manufacture.
- Project name and number.
- Arrow showing roll direction.

The plates shall be made of an all-weather resistant non-corrosive material.

## **8. Miscellaneous:**

- The cable manufacturer shall introduce and maintain a quality system according to ISO 9001.
- All optical fibers in each manufactured length shall be tested for attenuation according to Section 5.3. The measured attenuation coefficients (in dB/km) shall be provided with each cable reel.
- For lengths less than one kilometer, in consideration of test limitations, values that are within 0.05 dB of the specified end to end attenuation may be reported as the specification limit coefficient.
- At the request of the Employer, the cable manufacturer shall provide installation procedures, all necessary equipment for the installation process and technical support concerning the items contained in this specification.

## ANNEX F-2:

### **TECHNICAL SPECIFICATIONS OF OPTICAL FIBER CABLE - (G.652 D).**

- **AERIAL : (ADSS) TYPE**
- **LOOSE TUBES.**
- **DOUBLE OUTER JACKET.**
- **BLACK OUTER SHEATH.**

#### 1. General Considerations

All aerial optic fiber cables shall be of All-Dielectric Self Supporting (ADSS) type and have the configuration shown below. The aerial optic fiber cable shall be designed for stable optical performance at extreme temperatures where thermal expansion or contraction is negligible over a wide temperature range. The cable shall be ready to be installed on medium and low voltage electricity poles. The cable shall be installed on utility structures without interrupting power.

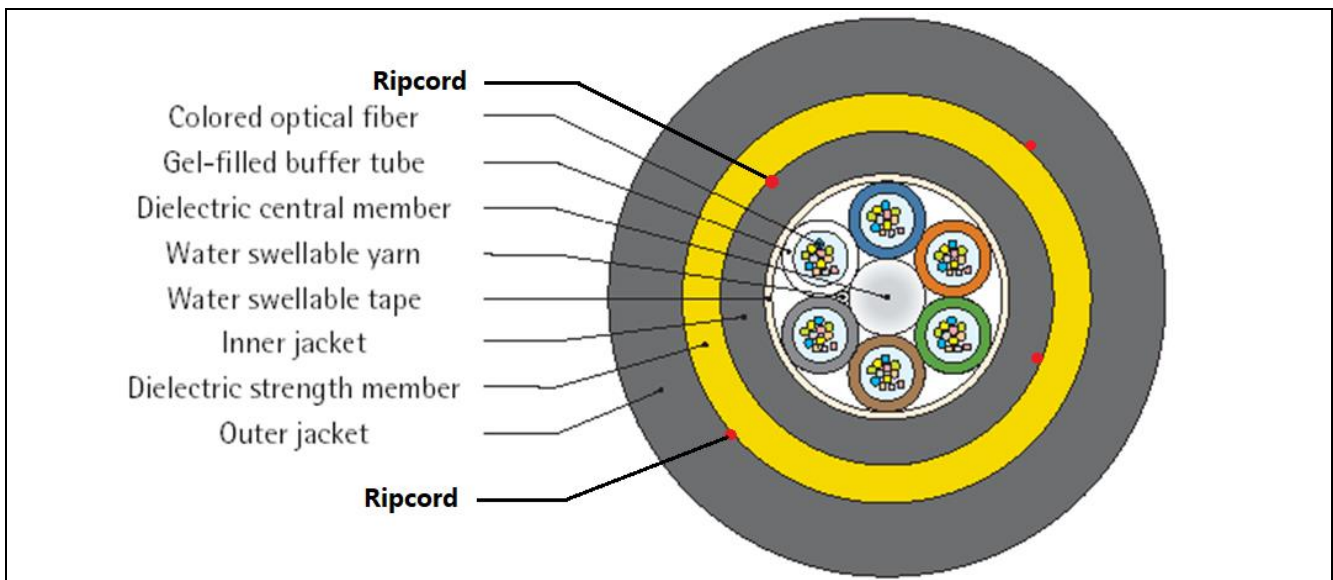

**All-Dielectric Self Supporting Optic Fiber Cable Components**

- This specification describes the cable design, properties of the fibers and the cable, the testing and the quality assurance during manufacturing, the final acceptance tests and the packaging.

- Single mode optical fiber cables which are optimized for use in both wave lengths windows of 1310 nm and 1550 nm are required. The optical fiber cables shall meet the requirements stated in ITU-T Rec. G.652 D.
- The cable shall be new, unused and of current design and manufacture.

## 2. Standards

- The specification refers to the following standards:
  - IEC60793-1: Optical Fibers - Part 1: Generic Specification.
  - IEC60793-2: Optical Fibers - Part 2: Product Specifications.
  - IEC60794-1: Optical Fiber Cables - Part 1: Generic Specification.
  - IEC60794-4: Optical Fiber Cables - Part 4: Sectional Specifications for OCEPL.
  - EIA/TIA 598: Color Coding of Fiber Optic Cables.

## 3. Fiber Characteristics

### 3.1. General Fiber Specifications

- The fibers shall meet all requirements according to IEC 60793-2 Category B1.
- All optical fibers shall be sufficiently free of surface imperfections and inclusions to meet the optical, mechanical, and environmental requirements of this specification.
- **Factory made optical fiber splices are not allowed.**
- Each optical fiber shall consist of a SiO<sub>2</sub> core doped with GeO<sub>2</sub> and a fused SiO<sub>2</sub> cladding (matched clad) giving a fiber with a step profile of the refractive index.
- The coating shall be easily strippable by means of a mechanical stripping tool without damaging the fibers. No chemicals shall be required.
- The fibers shall be completely phosphorus free.

### 3.2. Optical and Mechanical Characteristics of Standard Single Mode Fibers

- Single-mode Low Water Peak fiber shall be utilized in these optical fiber cables and shall meet the ITU recommendation G.652 D, "Characteristics of a Single-Mode Optical Fiber Cable".
- This requirement defines standard single-mode fibers for use across a broad wavelength range including the extended band (1360 nm - 1460 nm).
  
- These fibers shall have the specified performance and geometry values except as noted below:

<b>Mode field diameter (1310 nm):</b>	<b>9.2 <math>\mu\text{m} \pm 0.4 \mu\text{m}</math></b>
<b>Mode field diameter (1550 nm):</b>	<b>10.4 <math>\mu\text{m} \pm 0.5 \mu\text{m}</math></b>
<b>Cladding diameter:</b>	<b>125 <math>\mu\text{m} \pm 0.7 \mu\text{m}</math></b>
<b>Mode field concentricity error:</b>	<b><math>\leq 0.5 \mu\text{m}</math></b>
<b>Cladding non circularity:</b>	<b><math>\leq 0.8 \%</math></b>
<b>Refractive index profile:</b>	<b>step</b>
<b>Design:</b>	<b>matched cladding</b>
<b>Effective group index of refraction <math>N_{\text{eff}}</math> (at 1310nm):</b>	<b>1.4677</b>
<b>Effective group index of refraction <math>N_{\text{eff}}</math> (at 1550nm):</b>	<b>1.4682</b>
<b>Cut off wavelength of cabled fiber:</b>	<b><math>\leq 1260 \text{ nm}</math></b>
<b>Attenuation at 1310 nm:</b>	<b><math>\leq 0.35 \text{ dB/km}</math></b>
<b>Attenuation at 1383 nm:</b>	<b><math>\leq 0.35 \text{ dB/km}</math></b>
<b>Attenuation at 1550 nm:</b>	<b><math>\leq 0.22 \text{ dB/km}</math></b>
<b>Attenuation at 1625 nm:</b>	<b><math>\leq 0.24 \text{ dB/km}</math></b>

- The attenuation measurements shall be made after finally winding the cable on its shipping drum. Cable ends shall then be hermetically sealed.
- Each fiber in each cable delivery length shall have a zero-dispersion over the range 1300 - 1324 nm.
- Maximum chromatic dispersion at the wavelength 1330 nm shall not exceed 3.2 ps/nm.km or as pair ITU-T recommendation G.652 D.

### 3.3. Core Material

- The core of the optical fiber, with a higher refractive index compared to the cladding, is made of  $\text{SiO}_2$  (Silicon dioxide) doped with  $\text{GeO}_2$  (Germanium dioxide).

### 3.4. Cladding Material

- The cladding of the optical fiber is made of  $\text{SiO}_2$  (Silicon dioxide).

### 3.5. Type of Primary Coating

- The primary coating is made of an UV-curable acrylate. It is applied in two layers, each of a different Young's modulus.
- The inner layer is somewhat softer than the outer one.
- This make-up protects the fiber against micro bending losses and against abrasion.

### 3.6. Dimension of Primary Coating

- The dimension of the primary coating is  $245 \pm 5 \mu\text{m}$ .

#### Mechanical Characteristics of the Primary Coating

- The primary coating is easily strippable by means of a mechanical stripping tool. No chemicals shall be used.

### 3.7. Mechanical Characteristics of Fiber

- A nonmetallic central core shall be provided which may constitute the strength member designed to withstand all longitudinal stresses or its strength may be supplemented by an additional stress sharing sheath. The core shall be of a non-hygroscopic material.

Proof test stress:

- 8 N for 1 second; strain: 1 %.

Each optical fiber shall be proof tested by the fiber manufacturer at

- A minimum of 100 kpsi ( $0.7 \text{ GN/m}^2$ ).

Cable shall be able to contain 24 to 144F Colored fibers. Color coded binders shall be used to segregate the fibers into color coded groups. To the extent possible, colored fibers shall be segregated in groups of 12.

The loose buffer tube of the fibers shall be distinguishable by means of color coding in accordance with TIA/EIA-598-B, "Optical Fiber Cable Color Coding".

<b>Fiber Color Coding:</b>	fiber-# 1 : Blue	fiber-# 7 : Red
	fiber-# 2 : Orange	fiber-# 8 : Black
	fiber-# 3 : Green	fiber-# 9 : Yellow
	fiber-# 4 : Brown	fiber-# 10 : Violet
	fiber-# 5 : Slate	fiber-# 11 : Pink
	fiber-# 6 : White	fiber-# 12 : Turquoise

- The buffer tube shall be filled with a non-hygroscopic, non-nutritive to fungus, electrically non-conductive, homogenous gel in order to prevent water penetration and migration. The gel shall be free from dirt and foreign matter. The gel shall be readily removable with conventional nontoxic solvents.
  - The diameter of loose tube must be 2.5mm.
  - The central strength member shall be surrounded by a high density polyethylene (HDPE) jacket which shall have a bright color (e.g. orange, red, blue). The nominal jacket thickness shall be minimal 1 mm. The jacket shall not promote the growth of fungus.
- **The outer jacket:**
- The cable shall have two jackets, i.e. inner and outer jackets.
  - The jacket shall be continuous, circular, joints free, pinholes free, splits free, blisters free, or other imperfections. The jacket shall have a consistent, uniform thickness; pressure extruded jackets are not acceptable. Thickness of the sheath shall be uniform & shall not be less than 1.5 mm. The jacket shall be smooth, as is consistent with the best commercial practice. The jacket shall provide the cable with a tough, flexible, protective coating, able to withstand the stresses expected in normal installation and service.
  - Easy to strip.
  - A high-density polyethylene (Black HDPE) must make the outer jacket.
  - The outer jacket should be black of color.
  - Cable Diameter should be not less than 10mm.
- **RIP Cord:**
- Four suitable rip cords shall be provided in the cable, which shall be used to open the two HDPE sheath of the cable. The rip cords shall be placed diametrically opposite to each other. It shall be capable of consistently slitting the sheath without breaking for a length of 1 meter at the installation temperature. The rip cords (3 ply & twisted) shall be non-wicking type and shall not work as a water carrier.
- **Cable outer jacket shall be marked with:**
- Manufacturer's name, month and year of manufacture, sequential meter markings.
  - Telecommunication handset symbol
  - "MODEE-NBN" Ministry of Digital Economy and Entrepreneurship.as required by Section 350G of the National Electrical Safety Code® (NESC®),
  - Fiber count and fiber type.
  - The actual length of the cable shall be within +/- 1 % of the length markings.
- **The print color shall be contrast** with the cable jacket .The letters must be **engraved** on the Cable jackets clearly, not dimmed and the ink must be suitable for cable jacket material. The size of the marking letters shall be approximately 2.5 mm.

If the initial marking fails to meet the specified requirements (i.e., improper text statement, color, legibility, or print interval), the cable may be remarked using a contrasting alternate color. The



numbering sequence will differ from the previous numbering sequence, and a tag will be attached to both the outside end of the cable and to the reel to indicate the sequence of remarking.

- **Temperature range:**
  - Shipping and storage -40°C to +70°C
  - Operating temperature -40°C to +70°C
  - Installation temperature -5°C to +70°C

#### **4. General Cable Performance Specifications**

The cable shall fulfill the following mechanical, thermal and electrical characteristics. If applicable, during and after the tests, the attenuation shall be monitored at the operating wavelength.

##### **4.1. Tensile Performance**

- The cable shall be tested in accordance with IEC 60794-1-E1.
- The cable shall be able to withstand a permanent load (10 min) of > 9000 N.
- Short term load (1 min) of > 13000 N.
- Breaking tensile load of > 17000 N. No fibers shall exhibit a measurable change in attenuation after load removal.
- Also, the cable shall not have evidence of jacket cracking or splitting.

##### **4.2. Crush Resistance**

- The cable shall withstand a compressive long term load of 5000 N for duration of 10 minutes.
- Short term load of 6000 N for duration of 1 minute.
- The load shall be applied uniformly over the length of the compression plate.
- The crush resistance for the aerial optic fiber cables shall be 3000 N/100mm.
- The cable shall be tested in accordance with IEC 60794-1-E3. No fibers shall exhibit a measurable change in attenuation after load removal.

##### **4.3. Cable Bend**

- The minimum static bending radius of the cable shall be **more than 10 times the outer diameter.**
- The minimum dynamic bending radius of the cable shall be **more than 15 times the outer diameter.**
- It shall be tested in accordance with IEC 60794-1-E11. After the test there shall be no change in fiber attenuation greater than the uncertainty of measurement.

##### **4.4. Temperature Cycling**

The cable shall be subjected to

- Minimum temperature of -40°C.
- Maximum temperature of +70°C.
- The test shall be performed in accordance with IEC 60794-1-F1.
- The cable shall meet the temperature cycling test without exhibiting an average increase in fiber attenuation greater than 0.1 dB/Km for single mode fiber.
- This value includes the repeatability of the measurement system, which shall not be greater than +/- 0.05 dB.

#### **4.5. Water Penetration**

- A 1 m sample of the cable shall be subjected to a water penetration test according to IEC 60794-1-F5.
- After duration of 24 hours no water shall be detected at the open end of the cable core.

### **5. Testing**

#### 5.1. Type Test

- The type tests given in Section 6 shall be performed on the fiber optic cable.

#### 5.2. Factory Acceptance Test

- The cable performance shall be proved by showing detailed test reports of the optical attenuation (if applicable) during and after the test and all relevant test parameters of the type test.

#### 5.3. Routine Test

- The optical attenuation coefficient as required in Section 3.2 shall be verified at 1550 nm on all production cable lengths. The test shall be performed according to IEC 60793-1-C1C (Backscattering technique).

### **6. Quality Assurance Provision**

- The manufacturer shall carry out quality inspection and keep a record of the test results to an extent agreed.
- The manufacturer shall also have a trace ability of the materials used, and of the production steps, used in the manufacturing of the cable to an extent agreed.
- The supplier shall provide details of his quality control procedures that shall include the methodical recording of the results of production measurements.
- Test result shall include the following:

#### 1. Cable designation.

2. Number of fibers.
3. Fiber type.
4. Refractive index.
5. Drum no.
6. Length of cable.
7. Data of measurements.
8. Attenuation for every fiber at 1310 nm.
9. Attenuation for every fiber at 1550 nm.
10. Zero-dispersion wavelength for every fiber.
11. Zero-dispersion slope for every fiber.
12. Maximum and minimum value of mode field diameter of fibers in the cable.
13. Maximum and minimum value of cut-off wavelength in the cable.
14. A core-concentricity error of fibers in the cable.
15. Dispersion.
16. The test results shall be attached on the drum.

## **7. Packaging**

Cables shall be uniformly wound with no gaps between successive turns.

Cable ends shall be effectively sealed against physical damage, the ingress of water and loss of jelly filling, opening and re-sealing being possible at least ten times.

### **Identification of the cable drum shall include the following parameters:**

1. Name of manufacturer and month and year of production.
2. Cable designation and content.
3. Cable ID numbers.
4. Physical Cable length of cable and start and finish mark.
5. Order no.

6. Any other useful information.
  7. Attenuation per Km. of each fibre at 1310 & 1550 nm h).
  8. Group refractive index of fibres.
  9. Length of each fibre as measured by OTDR.
- 10. Each reel shall have a weather resistant reel tag attached identifying the reel and cable.**
- Drum size shall preferably be suitable for cable lengths **4000 m** as one piece.
  - Tenderers shall state the maximum drummed cable length of each cable type offered and the size and gross weight of loaded drums.
  - The cables shall be supplied on a wooden drum. Each length of cable shall be wound on a separate drum.
  - The diameter of the drum barrel shall be large enough to prevent damage to the cable during reeling or unreeling. The diameter of the barrel shall not be smaller than 40 times the outer diameter of the cable.
  - The drum shall be durable and constructed such as to prevent damage to the cables during shipment and handlings.
  - Lags or other suitable means of protection shall be applied to the drum to prevent damage to the cables during shipment and storage. Nails and staples used in the construction of the drum must not be placed in a position where they can damage the cables. The drums shall be non-returnable.
  - Drums with a ramp should be used. For test purposes, a length of approx. 4 - 5 m of the inner end shall be accessible.
  - The cable ends shall be sealed with shrinking caps and fastened tightly. A protective wrap shall be applied over the outer layer of the cable on each reel. The wrap shall be weather resistant and shall not be removed until the cable is installed.

**Marking plates, containing following information shall be securely attached to the outer side on each drum flange:**

- Type and size of cable.
- Cable length in meters.
- Gross weight in kilograms.
- Reel number.
- Manufacturer's name.
- Year of manufacture.
- Project name and number.
- Arrow showing roll direction.

The plates shall be made of an all-weather resistant non-corrosive material.

Identification of the cable drum shall include the following parameters:

1. Name of manufacturer and year of production.
2. Cable designation and content.
3. Cable ID numbers.
4. Length of cable and start and finish mark.
5. Order no.
6. Any other useful information.

Drum size shall preferably be suitable for cable lengths of at least 3000 m as one piece. Longer pieces are preferable.

Tenderers shall state the maximum drummed cable length of each cable type offered and the size and gross weight of loaded drums.

The cables shall be supplied on a wooden drum. Each length of cable shall be wound on a separate drum.

The diameter of the drum barrel shall be large enough to prevent damage to the cable during reeling or unreeling. The diameter of the barrel shall not be smaller than 40 times the outer diameter of the cable.

The drum shall be durable and constructed such as to prevent damage to the cables during shipment and handlings.

Lags or other suitable means of protection shall be applied to the drum to prevent damage to the cables during shipment and storage. Nails and staples used in the construction of the drum must not be placed in a position where they can damage the cables. The drums shall be non-returnable.

Drums with a ramp should be used. For test purposes a length of approx. 4 - 5 m of the inner end shall be accessible.

The cable ends shall be sealed with shrinking caps and fastened tightly. A protective wrap shall be applied over the outer layer of the cable on each reel. The wrap shall be weather resistant and shall not be removed until the cable is installed.

Marking plates, containing following information shall be securely attached to the outer side on each drum flange:

- Type and size of cable.
- Cable length in meters.
- Gross weight in kilograms.
- Reel number.
- Manufacturer's name.
- Year of manufacture.
- Project name and number.
- Arrow showing roll direction.

The plates shall be made of an all-weather resistant non-corrosive material

## **8. Miscellaneous**

- The cable manufacturer shall introduce and maintain a quality system according to ISO 9001.
- All optical fibers in each manufactured length shall be tested for attenuation according to Section 5.3.
- The measured attenuation coefficients (in dB/km) shall be provided with each cable reel.
- For lengths less than one kilometer, in consideration of test limitations, values that are within 0.05 dB of the specified end to end attenuation may be reported as the specification limit coefficient.

At the request of the Employer, the cable manufacturer shall provide installation procedures, all necessary equipment for the installation process and technical support concerning the items contained in this specification.

## **ANNEX F-3:**

### **TECHNICAL SPECIFICATIONS OF OPTICAL DISTRIBUTION FRAME (ODF).**

#### **Scope**

This specification covers the requirements for Optical Distribution Frames (ODF) to be used for termination of optical fiber cables in Technical Rooms where a large number of optical fibers are expected to be involved (Aggregate Points and Pops).

#### **1. Definitions**

- For the purpose of this specification the following definitions are applicable:

#### **Optical Distribution Frame (ODF)**

- The system required for the termination and/or through connection of optical fiber cables in an orderly, systematic and flexible way in order to gain simple and reliable access to the optical fibers.

#### **Patch Cord**

A specified length of tight-buffered optical fiber, with or without a strength member of aramid yarns stranded around the fiber and covered by an outer sheath, fitted with optical connectors at both ends.

#### **Pig-tail**

A specified length of tight-buffered optical fiber, with or without a strength member of aramid yarns stranded around the fiber and covered by an outer sheath, fitted with optical connectors on one end only. **And should be colored pig tails.**

#### **2. General Principles**

- The ODF should be given a dedicated location within an equipment area to facilitate an orderly collection and termination of optical fiber cables.
- Each optical fiber is terminated with an optical connector and accessed from a patch-panel at the ODF.
- It shall be possible to access each incoming optical fiber at the ODF and redistribute further to their final destination by the means of optical patch cords.
- Thus the ODF provides the flexibility point for all the optical cables involved, from where all fibers can be distributed, re-routed or cross-connected in a simple way, depending on the requirements and needs at any particular time.

## 1. Design

- 3.1. The ODF shall have a flexible and modular design, with provisions for future expansions, possibility to add new cables, or to remove existing ones. The parts and components shall be pre-assembled, as far as possible, in order to minimize the amount of work to be carried out at site when the ODF is installed.
- 3.2. The ODF shall comprise a system of racks, panels, etc. which shall be possible to order in units according to requirements, any other design arrangement may be offered. Suppliers may offer for wall mounted ODF with explanation to be provided.
- 3.3. The design of the ODF system shall take into account the handling properties of the optical indoor cable with special regard to the minimum allowed bending radius of the cable. At no place may the optical fibers be bent below a minimum allowed bending radius of 35 millimeters, and provisions shall be made in order to prevent the fibers from being squeezed anywhere in the rack.
- 3.4. It shall be reasonably simple to add new optical cables to the ODF and to install the corresponding patch-panels, etc. It shall be possible to carry out the work with a minimum of manpower using only common place tools.
- 3.5. The overall design shall be such that each optical connector is easy to access, connect or disconnect. Provisions shall be made to prevent accidental disconnection of optical connectors as well as physical damage to optical fibers due to unintentional mechanical influence (e.g. a ladder accidentally hitting the rack or patch panel).
- 3.6. Immediate access to the optical connectors shall be prevented by means of doors or panels. It shall be possible to lock or secure these to prevent unauthorized tampering with the connectors.
- 3.7. The ODF system shall include facilities for systematic and safe storage of excess lengths on optical patch cords. The minimum requirement is that it shall be possible to store at least 4 meters of excess length on each 3 mm diameter optical patch cord without causing excessive strain on the fibers.
- 3.8. The design and materials used for the ODF shall be compatible for use in a protected environment with controlled temperature and humidity and only occasional exposure to the temperature and humidity of a tropical coastal environment.
- 3.9. The ODF shall be of rack mounted type. Suppliers may offer as an option for wall mounted type.
- 3.10. The ODF shall be capable of operating over a full temperature range of (-30°C to +70°C), without any damage or significant change in performance.



### **3. Optical Connectors**

- The optical connectors to be used shall be of high-grade SC/UPC type as described below.

### **4. SC/UPC Connector Plug and Adapter**

- The optical fibers shall be terminated with PC-polished optical connector plugs of SC type.

#### 4.1. SC/UPC Adapter

- The patch panels of the ODF shall be furnished with adapters for optical connectors.

### **5. Splices**

Where splicing of pigtails is required by the ODF design the following shall apply:

#### 5.1. Facilities for Splicing

- For the protection and management of the fibers the ODF shall be furnished with splice trays or fiber organizers where the fiber joint shall be secured and excess fiber from the joint is stowed away.
- The splice tray design shall take into account the minimum allowed bending radius of 30 mm for the fiber.
- The strength member of the indoor cable shall be secured safely to the same shelf (unit, box, etc.) where the splice trays are installed. Unprotected primary coated fiber is not allowed anywhere in the rack except inside the protective cover of the splice trays.
- Tight buffered 0.9 mm fibers without additional protection shall also be protected and may only be used inside the patch-panels.

#### 5.2. Method of Splicing

- The optical pigtails, whether they are bare 0.9 mm tight-buffered fibers or have aramid yarn protection, shall be jointed by the means of fusion splicing, and the splices shall be protected by splice protection sleeve.

#### 5.3. Splice Loss

- The maximum allowed splice loss shall be  $\leq 0.1$  dB at 1310nm, and **not exceed than 0.07dB at 1550nm.**

## **ANNEX F-4:**

### **TECHNICAL SPECIFICATIONS OF MINI OPTICAL DISTRIBUTION FRAME AND ITS RELATED ACCESSORIES**

#### 1. Scope

This specification covers the requirements for Mini Optical Distribution Frames to be used for termination of optical fiber cables in Technical Rooms where a smaller number of optical fibers are expected to be involved (Connection Points).

##### 1.1. Definitions

For the purpose of this specification the following definitions are applicable:

##### Mini Optical Distribution Frame

The system required for the termination and/or through connection of optical fiber cables in an orderly, systematic and flexible way in order to gain simple and reliable access to the optical fibers.

##### 1.2. Patch Cord

A specified length of tight-buffered optical fiber, with or without a strength member of aramid yarns stranded around the fiber and covered by an outer sheath, fitted with optical connectors at both ends.

##### 1.3. **Pig-tail:**

- **Should be colored pig tails**
- A specified length of tight-buffered optical fiber, with or without a strength member of aramid yarns stranded around the fiber and covered by an outer sheath, fitted with optical connectors on one end only.

#### 2. **General Principles**

The Mini ODF should be given a dedicated location within an equipment area to facilitate an orderly collection and termination of optical fiber cables. The Mini ODF shall be placed into standard rack mount, and shall be suitable for most connectors and cable types. This unit contains space for pigtails, shelves, and patch panel.

Thus the Mini ODF provides the flexibility point for all the optical cables involved, from where all fibers can be distributed, re-routed or cross-connected in a simple way, depending on the requirements and needs at any particular time.

### **3. Design**

Mini ODF is used for applications in shared or growing networks. It is designed for splicing and cross-connecting fibers. The splicing function is handled by one or two cassettes, accommodating fusion splices protected by heat shrink sleeves. Connection and cross-connection are done by using any standard connector. The Sliding Patch & Splice Panel provides easy access to connections from the front of the frame, and accommodates left or right patch cord exit. The Mini ODF is ideal for use where networks may change more frequently or become complex.

- 3.1. The design of the Mini ODF system shall take into account the handling properties of the optical indoor cable with special regard to the minimum allowed bending radius of the cable. At no place may the optical fibers be bent below a minimum allowed bending radius of 35 millimeters, and provisions shall be made in order to prevent the fibers from being squeezed anywhere in the rack.
- 3.2. The overall design shall be such that each optical connector is easy to access, connect or disconnect. Provisions shall be made to prevent accidental disconnection of optical connectors as well as physical damage to optical fibers due to unintentional mechanical influence (e.g. a ladder accidentally hitting the rack or patch panel).
- 3.3. Immediate access to the optical connectors shall be prevented by means of doors or panels. It shall be possible to lock or secure these to prevent unauthorized tampering with the connectors.
- 3.4. The design and materials used for the ODF shall be compatible for use in a protected environment with controlled temperature and humidity and only occasional exposure to the temperature and humidity of a tropical coastal environment.
- 3.5. The Mini ODF shall be capable of operating over a full temperature range of (-30°C to +70°C), without any damage or significant change in performance.

#### **4. Optical Connectors**

- The optical connectors to be used shall be of high-grade SC/UPC type as described below.

##### **4.1. SC/UPC Connector Plug and Adapter**

- The optical fibers shall be terminated with PC-polished optical connector plugs of SC type.

##### **4.2. SC/UPC Adapter**

- The patch panels of the Mini ODF shall be furnished with adapters for optical connectors.

## 5. Splices

Where splicing of pigtails is required by the Mini ODF design the following shall apply:

### 5.1. Facilities for Splicing

- For the protection and management of the fibers the Mini ODF shall be furnished with splice trays or fiber organizers where the fiber joint shall be secured and excess fiber from the joint is stowed away.
- The splice tray design shall take into account the minimum allowed bending radius of 30 mm for the fiber.
- The strength member of the indoor cable shall be secured safely to the same shelf (unit, box, etc.) where the splice trays are installed.
- Unprotected primary coated fiber is not allowed anywhere in the rack except inside the protective cover of the splice trays.
- Tight buffered 0.9 mm fibers without additional protection shall also be protected and may only be used inside the patch-panels.

### 5.2. Method of Splicing

The optical pigtails, whether they are bare 0.9 mm tight-buffered fibers or have aramid yarn protection, shall be jointed by the means of fusion splicing, and the splices shall be protected by splice protection sleeve.

### 5.3. Splice Loss

- The maximum allowed splice loss shall be  $\leq 0.1$  dB at 1310nm, and **not exceed than 0.07dB at 1550nm.**

## **ANNEX F-5:**

### **TECHNICAL SPECIFICATIONS OF OPTICAL CONNECTORS AND ADAPTERS**

#### 1. Scope

This document specifies the requirement of optical connector sets of SC/UPC-type to be used in single-mode optical fiber telecommunication systems.

A connector set is: "The complete set of connector components required to provide demountable coupling between optical fibers". The length of fiber or cable on each side of the connector set shall be 3 meters (minimum).

#### 2. Design

##### 2.1. General

The ferrule of the optical connector shall be made of zirconia stabilized ceramic.

When the connector is mounted on a cable (or a tight buffered fiber) the fiber shall be fixed with epoxy in the cavity of the ferrule. Then the end face of the ferrule with the fiber shall be polished. In order to ensure physical contact the shape of the ferrule shall be spherical.

The cable (jacket and strength members) shall be fixed to the connector by means of a crimp sleeve.

Mating with another connector shall be accomplished by the means of an adapter with a split sleeve.

##### 2.2. Material

The supplier shall give details of the materials used in different parts of the proposed connector.

The connector housing shall be of an all-metal design.

##### 2.3. Ferrule

The ferrule end face shall be UPC-polished and meet the following requirements:

Ferrule end face curvature (r)	$10 < r < 25 \text{ mm}$
Vertex offset of ferrule tip (convex vertex eccentricity from ferrule center)	$< 50 \text{ }\mu\text{m}$
Fiber undercut from ferrule end face:	$\leq 0.05 \text{ }\mu\text{m}$

Fiber protrusion from ferrule end face:	$\leq 0.10 \mu\text{m}$
Outside diameter (A)	$2.4990 \pm 0.0005 \text{ mm}$
Tolerance of cavity diameter	+1, -0 $\mu\text{m}$
Concentricity error C.E. of cavity	$< 1.4 \mu\text{m}$
Angular misalignment $\Theta$	$< 0.2^\circ$

### 3. Performance Requirements

#### 3.1. Visual Inspection

##### 3.1.1. Overall Inspection of Connectors

Each connector shall be properly packed. The package shall be marked with, the name of the manufacturer and the manufacturing date.

The connector itself shall be legibly and durably marked with the identity mark of the manufacturer and the manufacturing date code.

##### 3.1.2. Inspection of the End Face

The end face shall be clean and free from residues of glue. Using a microscope with a maximum magnification of 200x no scratches or break out of glass pieces shall be seen.

#### 3.2. Insertion Loss

Requirements:

	Mean	Maximum
Allowable attenuation:	$\leq 0.25 \text{ dB}$	$\leq 0.50 \text{ dB}$

#### 3.3. Return Loss

Requirements:

Allowable return loss:	$\geq 40 \text{ dB}$
------------------------	----------------------

### 4. Temperature

The connector shall be capable of operating over a full temperature range of (-30°C to +70°C), without any damage or significant change in optical performance.

## **ANNEX F-6:**

### **TECHNICAL SPECIFICATIONS OF OPTICAL CABLE SPLICE ENCLOSURES**

#### 1. Scope

This specification covers the requirements of splice enclosures to be used for splicing of all types of optical cables. Thus it is applicable for both duct and aerial cables.

#### 2. General

The design of the splice closure shall consider ITU-T recommendation L.13 “Sheath joints and organizers of optical fiber cables in the outside plant” and the requirements of this specification.

It shall be possible to use the splice closure installed in manholes, in handholes, on poles, in cable vault, etc. It is the intention to use the splice closure to be installed in chambers or on poles.

The closure shall be re-enterable, i.e. possible to open and close several times, without wear or impairment of its water tightness and/or other essential features.

The closure shall be equipped with fiber cassettes and organizers that are easy to use and which provide full protection to the fibers.

#### 3. Handling Aspects

3.1. The splice closure shall have a robust and reliable design and well adapted to the conditions in the field. It has to work even if minor un-intentional deviations at the installation procedure are made.

3.2. The splice closure shall have as few parts as possible.

3.3. Tools that require calibration should not be required for work with the closure.

3.4. The use of melt resin or glue shall be avoided if possible.

3.5. Work with the closure shall be possible in a cramped room, e.g. manholes.

3.6. Work with the closure shall be possible without bending the fibers below their minimum allowed bending radius at any stage of work.



- 3.7. Work with the closure shall not require extensive training.
- 3.8. Work with the closure shall be possible to be carried out by one man alone.
- 3.9. Work with the closure shall not involve any risk of injury to the working personnel.
- 3.10. The method of work shall be described in an easy to understand installation instruction or manual enclosed with each closure in English and Modern Standard Arabic.
- 3.11. All the parts of the splice closure, except for the materials required for jointing of the fibers, shall be packed in one package, with a clear marking of its contents if required. If the storage time is limited that shall be stated on the package.

#### 4. Design

The contractor shall furnish and install fiber optic splice closures in locations where splices require protection as shown on the plans and as ordered by the Engineer. The fiber optic splice closure shall meet all requirements stated in the following specification:

- 4.1. The splice closure shall provide a good mechanical protection.
- 4.2. The splice closure shall incorporate a mechanical compression and/or mastic tape sealing system to maintain a barrier against water and moisture penetration.
- 4.3. The splice closure shall be reasonably resistant against unauthorized tampering, vibration and wear, as well as against biotic attack (rodents, termites, etc.).
- 4.4. The splice closure shall be resistant against corrosion.
- 4.5. The splice closure shall be resistant against UV-radiation.
- 4.6. The splice closure shall be made of materials, which are mutually compatible.
- 4.7. The size of the splice closure shall be in proportion to the number of cables, fibers in each cable and to the number of splices.
- 4.8. It shall be easy to re-enter the splice closure and close it again several times. Also the closure shall be capable of accepting additional cables without removal of the sheath retention or strength member clamping hardware on previously installed cables or disturbing existing splices.
- 4.9. Bolts should not rust due to weather factors (galvanized).

- 4.10. The design of the closure must be such that the fibers are never bended below their minimum allowed bending radius of 35 mm during any phase of the splicing work.
- 4.11. A splice closure, which shall be used for a branching joint, shall be possible to assemble without the necessity to cut all the fibers.
- 4.12. The fiber optic closure shall be available in distinct sizes to accommodate a variety of cable entries. A fiber optic closure shall be capable of accommodating at least **four entry ports** in a butt or branch configuration, and suitable for different diameters of cables.



- 4.13. It shall be possible to split and branch groups of 6 fibers from the splice closure.
- 4.14. Inside the splice closure there shall be space enough for an excess length of fiber of at least 2 meters. This length is based on expected future needs for maintenance or redistribution of fibers.
- 4.15. The splice closure shall contain, or have the space for, fiber organizers for storage of fiber joints as well as the excess lengths on fibers.
- 4.16. The fiber organizers shall provide good protection to the fibers and their joints, and have space for identification of each fiber.
- 4.17. The splice closure together with the fiber organizer shall facilitate easy access to any optional fiber within the closure for work without affecting the service on the other fibers.
- 4.18. In the splice closure it shall be possible to terminate any possible metallic conductor in the optical cable in such a way that they are easily accessible and possible to equip with over voltage protection devices.
- 4.19. The splice closure shall be possible to use on cables with basically a circular cross-section and shall be adapted to the dimensions of the cables to be connected.
- 4.20. The splice closure shall provide satisfactory anchorage of the jackets, armoring and strength members of the cables.
- 4.21. The splice closure shall allow metallic parts of the cables, if any, to be bridged over so that a satisfactory electrical connection between them is achieved. It shall be possible to ground metal parts of the cable, and it shall also be possible to separate all the metal parts.
- 4.22. For manhole installation it shall be possible to attach the splice closure to a manhole wall by the means of attachment devices, as shown in the figure below, all necessary materials for all-necessary materials for fixing shall be included in the offer.



### **Splice Closures for Duct Cable**

- 4.23. It shall be easy to re-enter the splice closure and close it again several times. In addition, the closure shall be capable of accepting additional cables without removal of the sheath retention or strength member clamping hardware on previously installed cables or disturbing existing splices.
- 4.24. The design of the closure must be such that the fibers are never bended below their minimum allowed bending radius of 35 mm during any phase of the splicing work.
- 4.25. A splice closure, which shall be used for a branching joint, shall be possible to assemble without the necessity to cut all the fibers.

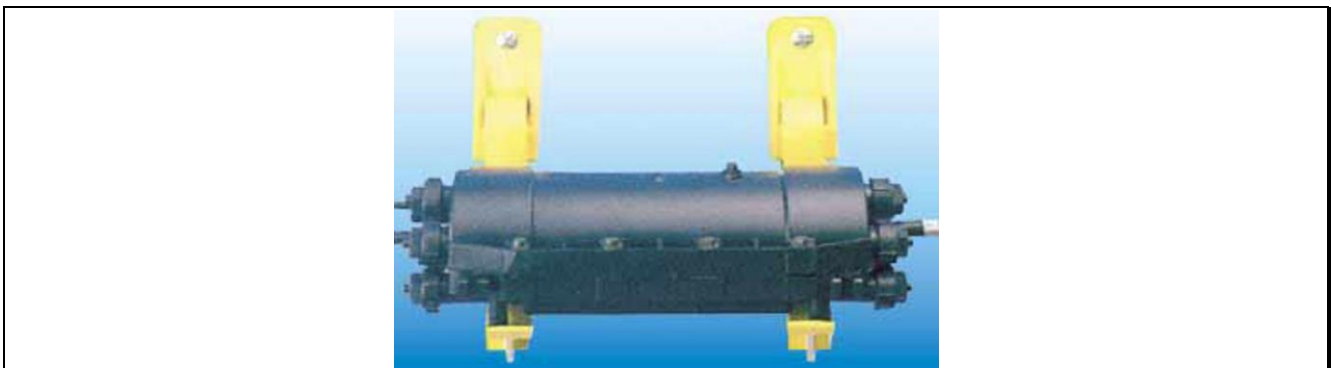

### **Example of a Splice Closures for Duct Cable**

- 4.26. For pole installation it shall be possible to attach the splice closure to the pole by the means of attachment devices, as shown in the figure below, all necessary materials for fixing shall be included in the offer.

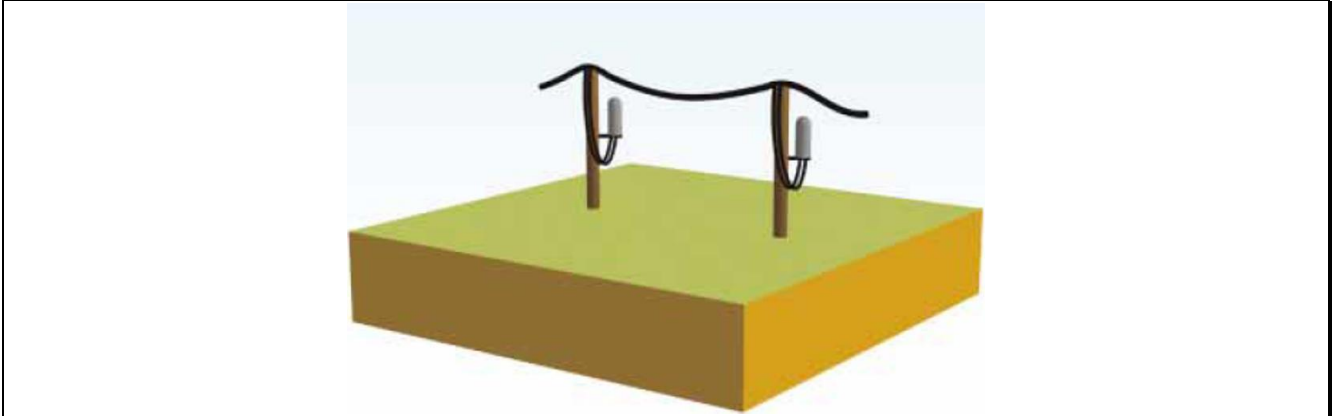

**Splice Closures for Aerial Cable**



**Example of a Splice Closures for Aerial Cable**

- 4.27. It shall be easy to furnish the splice closure with an external marking.
- 4.28. The splice closure shall be capable of operating over a full temperature range of (-30°C to +70°C), without any damage or significant change in performance.

**ANNEX F-7:**

**TECHNICAL SPECIFICATIONS FOR DUCT CABLE HARDWARE AND SUPPORT ACCESSORIES**

1. Cable U-Guard shall be used to protect the cable at the points of potential abrasion.

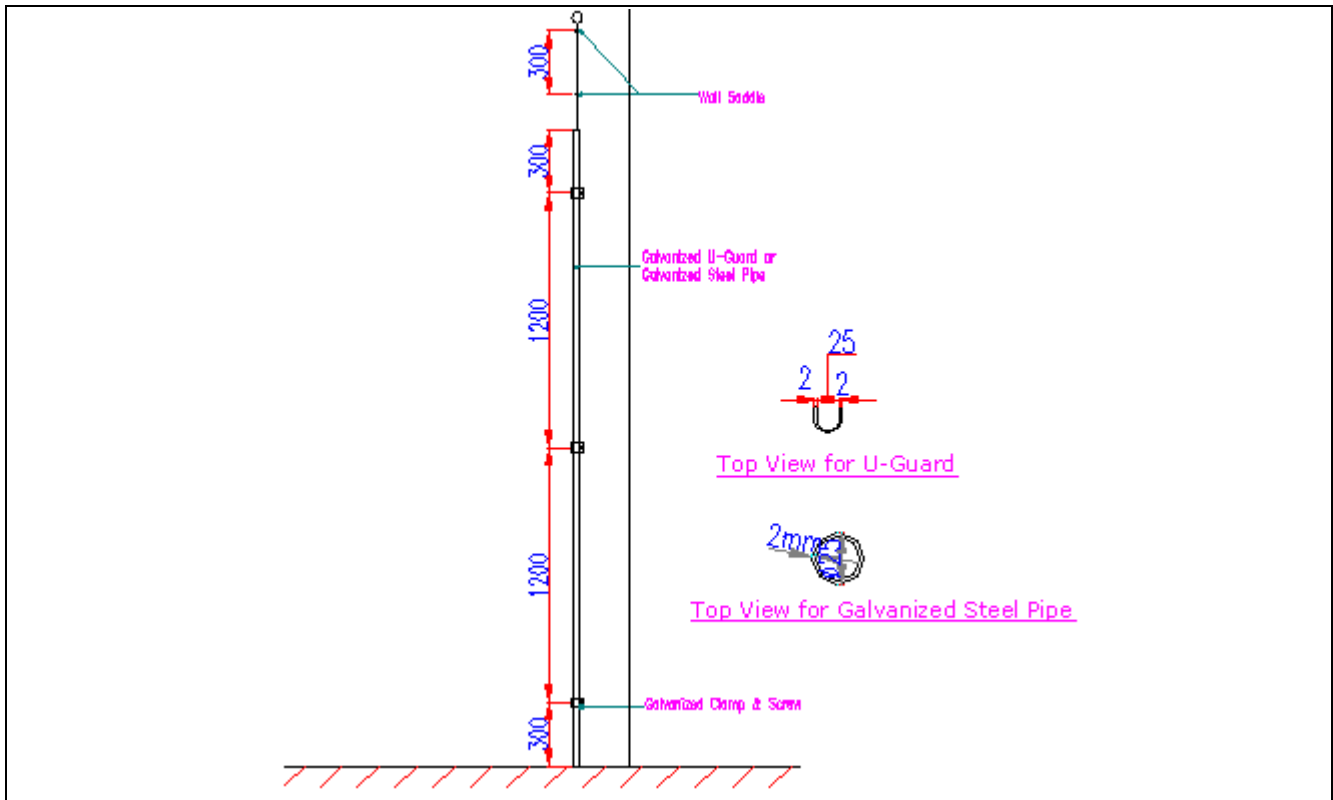

**U-Guard or Galvanized Steel Protector Pipe**

2. Cable trays with cover shall be used to protect cables installed on wall.
3. Cable Tray/U-Guard installations shall be carried out with no damage to the wall surface.

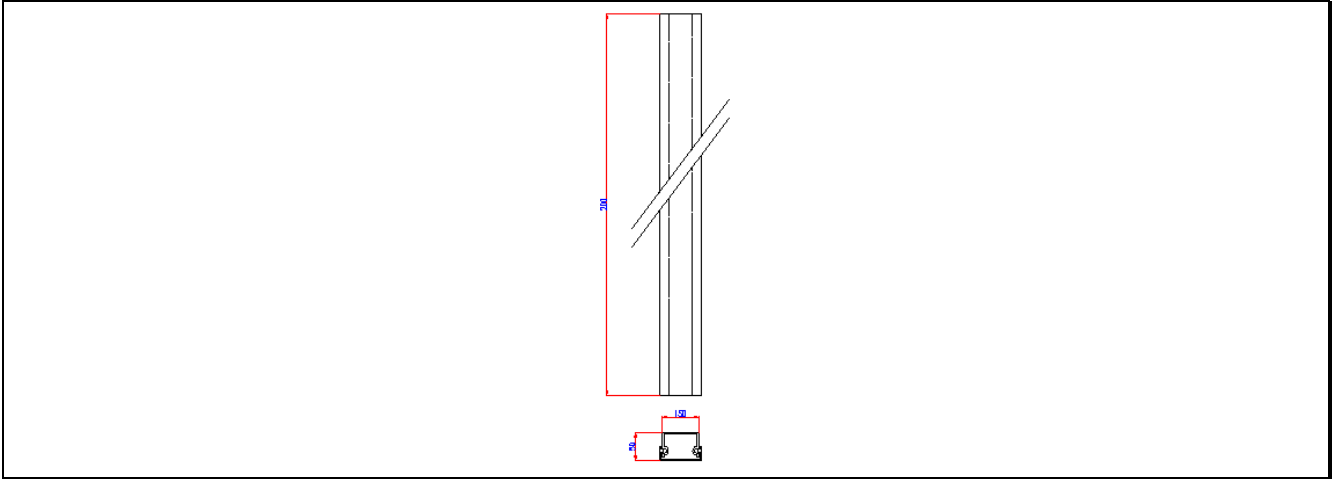

**Side & Top View for Galvanized Steel Cable Tray with Cover**

4. Corrugated rigged tube ( $\text{Ø } 22 \text{ mm}$ ) shall be used to protect fiber optic cables in manholes, handholes, pull boxes, and at building entrances.



**Corrugated Rigged Tube ( $\text{Ø } 22 \text{ mm}$ ) & Accessories**

5. Wall mounted bracket for splice box to be installed inside Manholes or Hand holes, the bracket should be fitted to the splice box supplied by the contractor.

## **ANNEX F-8:**

### **TECHNICAL SPECIFICATIONS FOR AERIAL CABLE HARDWARE AND SUPPORT ACCESSORIES**

#### 1. Cable Storage

All slack cable storage locations require the installation of slack cable storage brackets. The fiber cable storage bracket insures a proper bending radius for the stored fiber optic cable and provides for horizontal storage and tie ring for storage of multiple cables and loops. The figures below illustrate possible slack cable storage configurations.

There are two general types of aerial cable support hardware: Figure\_8 -Aerial Cable Storage and Cross - Aerial Cable Storage. these types differ each other and the supervision engineer decide which type should be used..

##### 1.1 Figure\_8 - Aerial Cable Storage

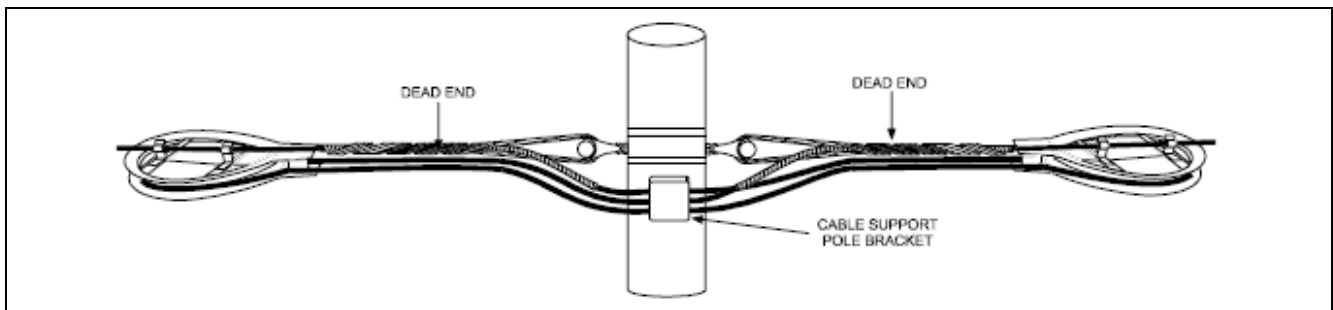

**Figure\_8 - Aerial Cable Storage Configuration for Pass-Through Cables**

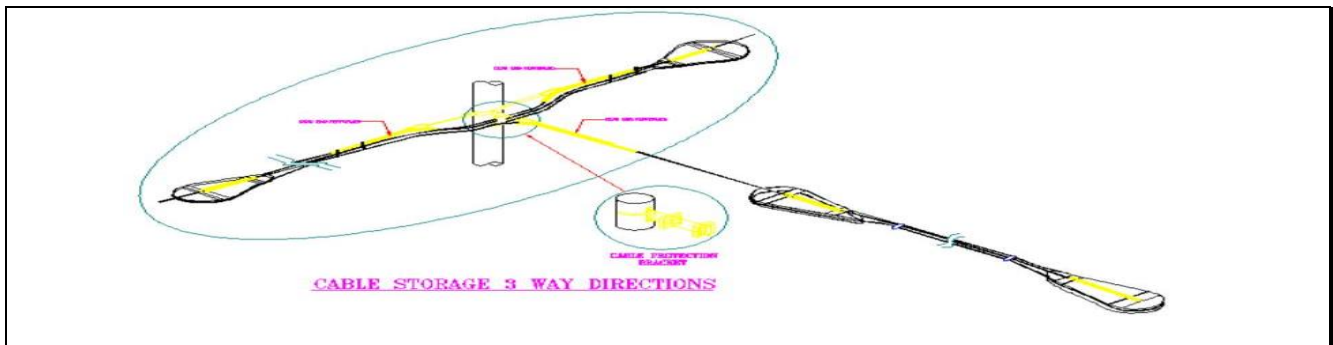

**Figure\_8 - Aerial Cable Storage Configuration for Angled Cables**

##### 1.2 Cross - Aerial Cable Storage





**Figure\_8 - Aerial Cable Storag**



**Cross - Aerial Cable Storage Configuration for Angled Cables**

## 2. Aerial Cable Support Hardware

There are two general types of aerial cable support hardware: Dead-end and tangent (pass-through) assemblies.

### 2.1. Dead-end Grip

Dead-end bracket is used at the point of cable termination. The figure below shows an aerial cable dead-end Grip.

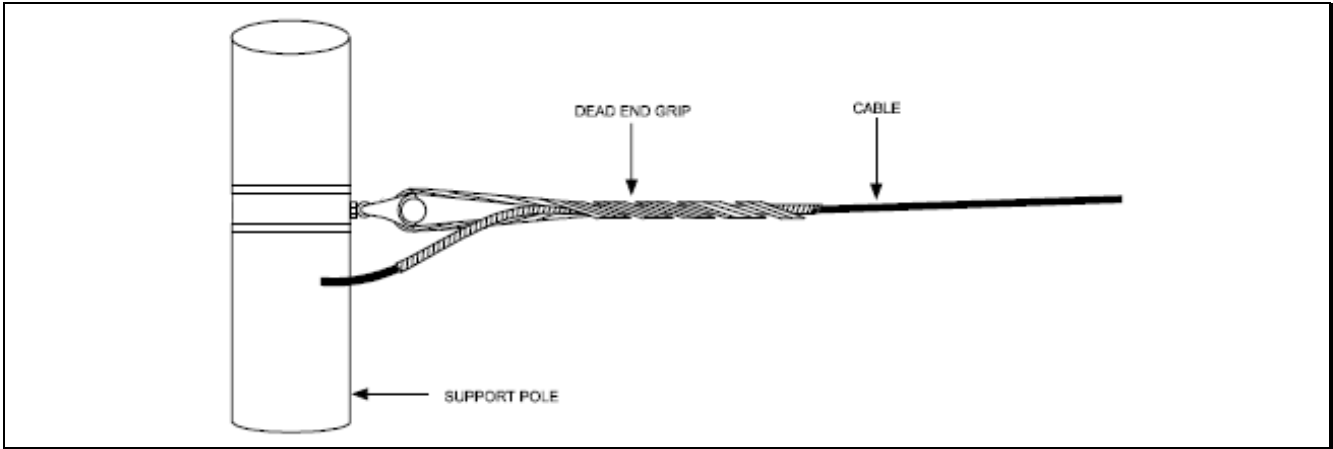

**Aerial Cable Dead-end Grip**

2.2. Pass-Through Bracket

Pass-through bracket is normally installed after the span has been tensioned. The figure below illustrates a front view of a pass-through bracket. To install the cable, the hinged top is opened and the bottom pad is inserted. Then the cable is placed on the pad, the top pad is placed over the cable, the top is closed, and the bolt is tightened to hold the cable in place.

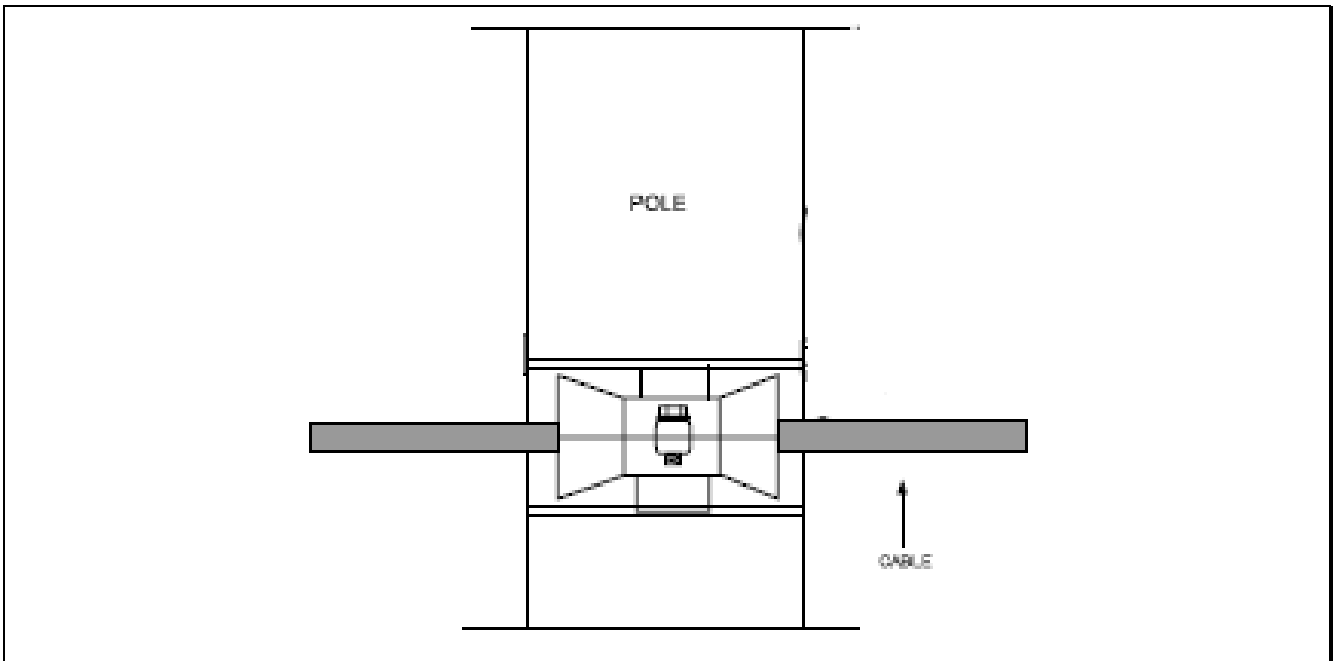

**Pass-Through Bracket**

3. Cable Mounts

Cable mounts is normally used to hold the aerial cable on the pole (wooden, steel, concrete).

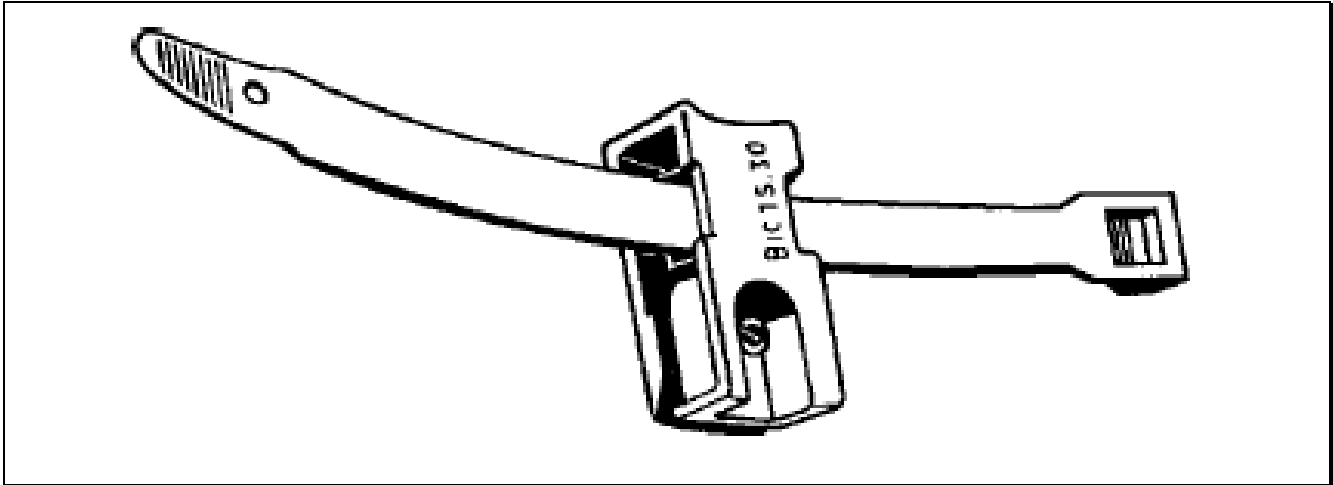

**Aerial Cable Mount (for Steel, Concrete, and Wooden Poles)**

4. Splice Closures Clamp

Strapped clamp is normally used to hold the closures on poles (wooden, steel, concrete) as shown in figure below.

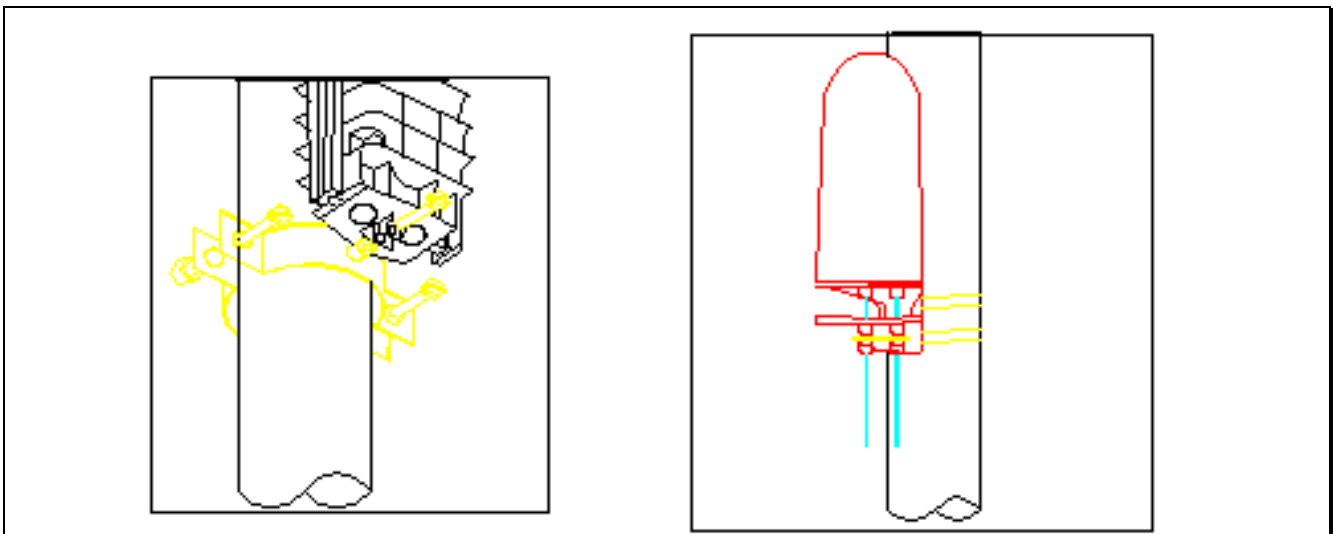

**Splice closures clamp strapped with metal bends**

5. Galvanized Pipe Holder

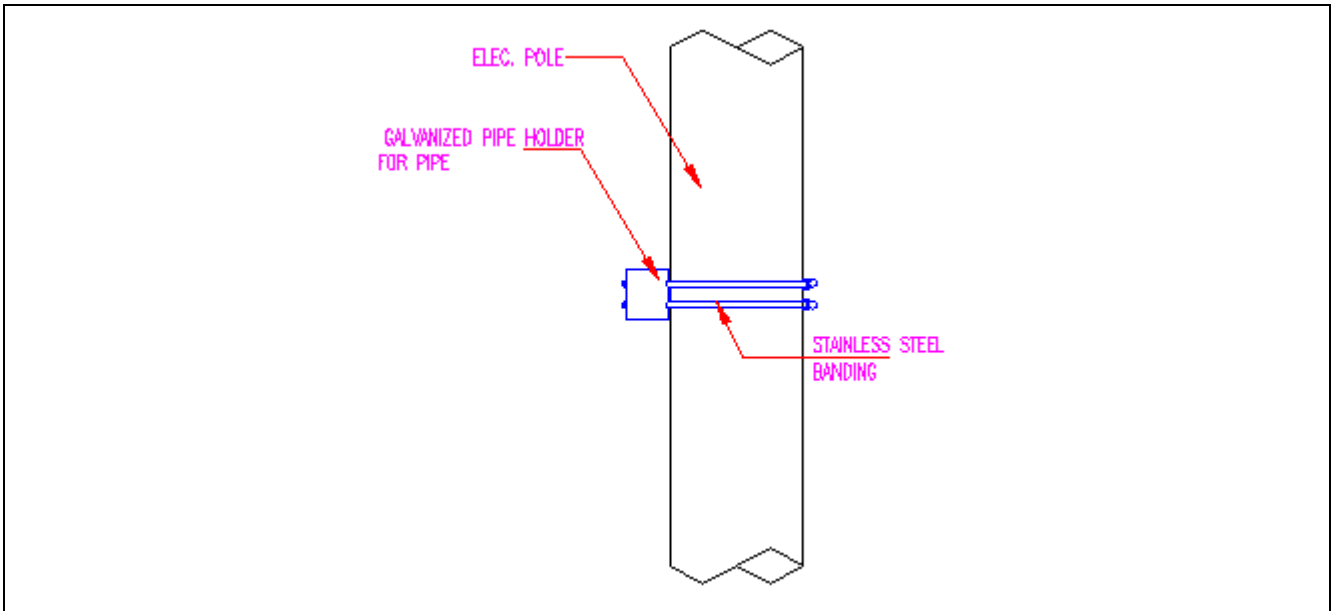

**Galvanized Pipe (Ø 25, 50 mm) Holder**

## **ANNEX G:**

### **AERIAL CABLE SAG AND CLEARANCE:**

Planning for aerial cable installation includes taking into account proper clearances, cable types and properties, the mechanical stress loading on the cable, and span length.

- Medium Voltage Network

Planning for proper clearances requires knowing the “sag” of the proposed installation. The Contractor shall plan aerial cable installation to allow for a minimum clearance of five (5) meters above ground level and three (3) meters from existing medium voltage power cables at the electricity poles, which may be reduced to 2m to guarantee the 5m clearance above the ground. The minimum clearance (Worst Case) of the mid-point of the fiber optic cable (max. sag location) should not be less than one (1) meter from the mid-point of electrical cable (max. sag location).

- Low Voltage Network

Clearance distance of the fixing point of fiber optical cable on the pole to EDCO Network (electrical conductors) has been set at one (1) meter.

- Installation conditions

In some special cases where the clearance between the fiber optical cables and the ground level is less than five (5) meters conjunctively, the distance of the fixing point of fiber optical cable on the pole EDCO Network (electrical conductors) is two (2) meters, then poles must be erected at the mid spans or otherwise as required (If technically possible and Landowners, Municipalities, Public works agree for the route) , the newly installed poles shall be erected at an offset of one (1) meter of the alignment of the existing EDCO poles (If the route is available and Landowners, Municipalities, Public works etc...agree for this solution). The new poles will be erected at locations where transformer substations are installed at 33 KV and 11 KV line poles and are envisaged to obstruct the installation of the fiber optic cable within these locations.

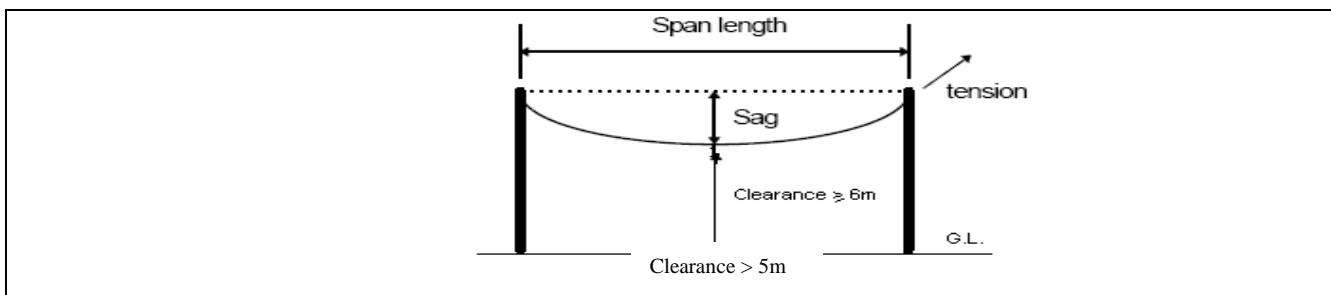

**Aerial Cable Sag and Clearance**

## **ANNEX H: TEST AND ACCEPTANCE SPECIFICATIONS**

### **1. General Requirements**

Tools and test instruments required for the acceptance shall be provided by the Contractor and all costs for buying these tools and test performance are to be included in the Contractor's unit rates and shall be fully described and identified by:

- Manufacturer.
- Type.
- Option(s) installed.
- Serial number.
- Last date of calibration.

The test instruments shall be adequate in both performance and quantity for the required acceptance testing. The offered test instruments shall conform to the O-Series of ITU-T Recommendations. All test instruments should have a valid calibration label stating calibration institution and expiration date.

A copy of the instruction manual shall be provided with each test instrument during the acceptance testing. The manuals shall contain all the relevant information for each type of the test instruments offered, including operation, fault diagnosis and correction, recalibration test, standards and recalibration instruments required.

The test instruments shall include all necessary power cords, patch cords, attenuators, test probes and accessories to carry out all the tests. All accessories required for performing the acceptance test should have been included in the calibration procedure.

### **2. Tests of Cable and Measurements of Optical Signal Attenuation**

#### **2.1. *General***

All adjustments to the costs for the installation of the outside plant fiber optic cables will be performed from physical segment lengths, explicitly excluding losses due to cable installation and or other manipulation. This shall make it possible to validate installed segment lengths against optical lengths from the test equipment.

#### **2.2. *Acceptance Tests***

The optical fiber acceptance tests are comprised of measurements of signal strength through signal reflection (Optical Time Domain Reflectometer, OTDR) and signal insertion and detection. The Contractor shall perform all acceptance tests and compile them on the required forms. The Contractor shall submit to the Engineer all forms necessary to detail the performance of each fiber. The Contractor shall invite the Engineer to witness the final tests.

## *Laser Source Verification Procedure with Simple Signal Insertion and Detection Tester*

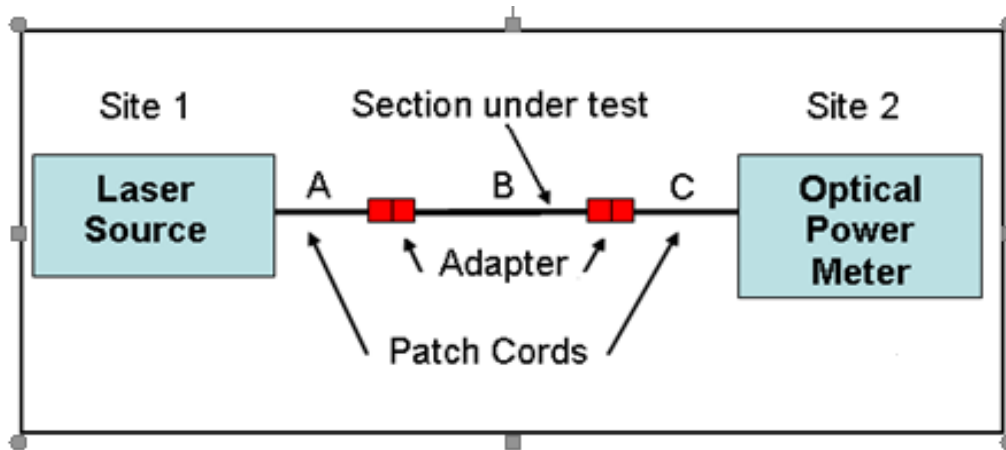

**NOTE:** No two lasers have the same output value. It is necessary to precisely measure this output value in order to determine the signal loss caused by the patch cords and the connectors. In knowing the precise output value, it is then possible to subtract it from the final read out. The readings must be performed on both the transmit (Tx) and receive (Rx) fiber strands, and in both directions by inverting the source and the sensor. This calibration test must be performed prior to any measurement being taken.

### **EXAMPLE:**

A = Reference signal of the source

B = Reference signal of the sensor

C = Adaptor

Step 1 = First reading composed of:  $A + C + B = -3.5$  dBm

Step 2 = Inversion of source and sensor

Step 3 = Second reading composed of:  $B + C + A = -2.8$  dBm

Step 4 =  $(-3.5) + (-2.8) = -6.3$  dBm divided by 2 =  $-3.15$  dBm

*Therefore, we have a reference loss of: -3.15 dBm (example value)*



### Example of Measurement on a Section (B)

The reading from Site 1 to Site 2 = **-18.7 dBm**

$-18.7 - (-3.15)$  (see previous section) = **-15.55 dBm**

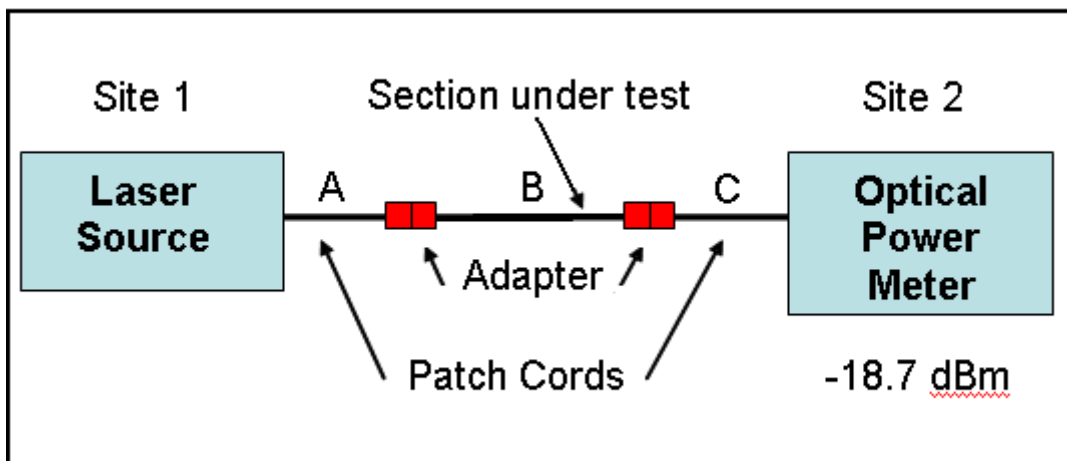

The reading from Site 2 to Site 1 = **-19.5 dBm**

$-19.5 - (-3.15) = -16.35$  dBm

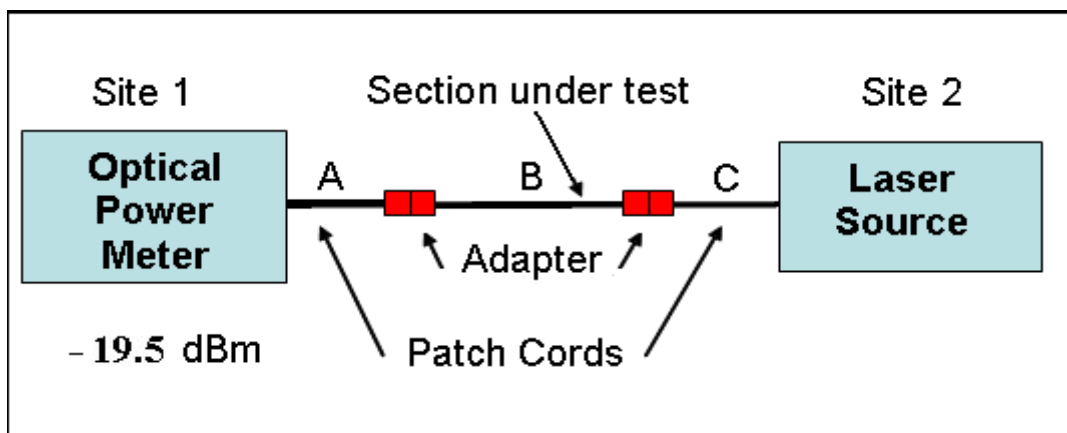

**NOTE:** Each reading must be performed in both directions. The result is divided by two (2) to obtain the real value.

$(-15.5) + (-16.35) = -31.85$  dBm divided by two = **-15.93 dBm**

*Therefore, the real loss on this section (B) is -15.93 dBm (example value)*

### Examples of Signal Attenuation Readings Records (loss in dB)

These readings shown in the table below have been taken only in one direction and should be repeated in the other direction.

OUTPUT SOURCE POWER: (example)				
At 1310nm = -1dbm At 1550nm = -3dbm				
A to B	Measure at 1310	Measure at 1550	Real loss at 1310	Real loss at 1550
F # 1	-15.7	-11.8	-14.7	-8.8
F # 2	-15.7	-12.09	-14.7	-9.09
F # 3	-15.99	-11.48	-14.99	-8.48
F # 4	-15.62	-11.96	-14.62	-8.96
F # 5	-15.82	-11.8	-14.82	-8.8
F # 6	-15.81	-11.72	-14.81	-8.72
F # 7	-15.85	-12.16	-14.85	-9.16
F # 8	-15.71	-12.06	-14.71	-9.06
F # 9	-15.71	-12.06	-14.71	-9.06
F # 10	-15.71	-12.06	-14.71	-9.06
F # 11	-15.71	-12.06	-14.71	-9.06
F # 12	-15.71	-12.06	-14.71	-9.06
F # 13	-15.71	-12.06	-14.71	-9.06
F # 14	-15.71	-12.06	-14.71	-9.06
F # 15	-15.71	-12.06	-14.71	-9.06
F # 16	-15.71	-12.06	-14.71	-9.06

All measurements must be saved on paper and in electronic copy in Microsoft Excel format. The real loss data should be entered in the attached acceptance sheet (MS Excel spreadsheet). The acceptance criteria for cable loss measurement are detailed on this sheet.

### 3. Readings with Optical Time Domain Reflectometer (OTDR)

When measuring attenuation, it is necessary to consider splices, which increase the signal (positive splices), and splices, which decrease the signal (negative splices).

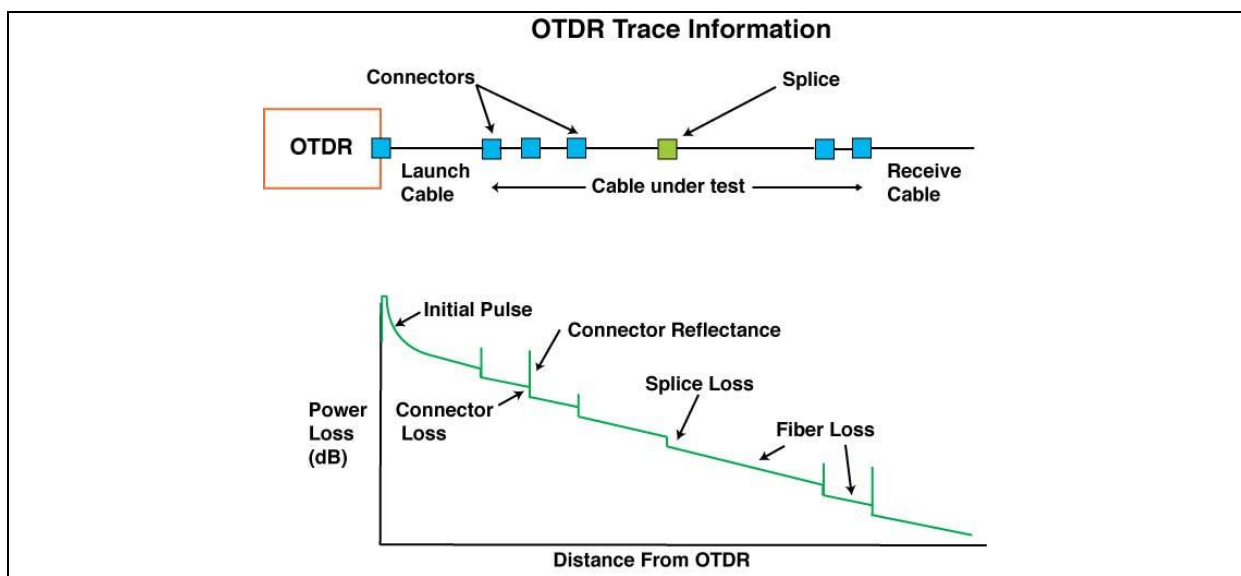

**Ex:** (0.08db) positive and (-0.06db) negative

In order to obtain the net loss value of a splice, it is necessary to measure the signal in both directions, add the two (2) values and divide by two (2).

***In the aforementioned example, the final result would be: (0.08) + (-0.06) = 0.02 dB divided by two = 0.01 dB***

### ***Maximum Attenuation of a Fusion***

The maximum attenuation for a fusion shall be of **0.1 dB** at a **1310** nanometer wavelength and of **0.06 dB** at a **1550** nanometer wavelength.

The total attenuation for a kilometer of network (dB/km) shall correlate with the specifications of the fiber optic cable manufacturer.

The true optical distance (including all slack in the cable) must be specified for each measurement; in all attenuation test reports (see Excel spreadsheet).

Paper print out of the OTDR measurements showing the complete distance and electronic files (taken from both directions on the fiber section) should be included in the acceptance report. The electronic files should be supplied with the software to run on a standard PC to open and read and display the files.

#### ***4. Additional Optical and Dispersion Measurements***

Dispersion measurements shall be made within the dynamic range of the test equipment.

- a. Each fiber in each cable delivery length shall have a zero-dispersion over the range 1300-1324 nm (< 3.5 ps/nm.km). Maximum dispersion at the wavelength 1550 nm shall not exceed 18 ps/nm.km or as pair ITU-T recommendation G.655.
- b. Polarization Mode Dispersion should also be verified to guarantee future extreme high bit-rate operation (> 10 Gb/s). The PMD should have be less than 0.1 ps/sqrt(km) at 1550 nm.

In case the tests cannot be executed due to test equipment not being available in country, the Factory Acceptance Test sheets of the cable installed should be provided.

#### ***5. Fiber Acceptance Report***

The fiber acceptance report shall be handed over on 3 paper copies and 3 electronic copies on CD-ROM and prepared for each optical fiber cable section between the optical termination points. The acceptance report shall contain the following items.

##### ***5.1. Acceptance Report Components***

### ***General Test Identification***

- Optical fiber cable section identifier.
- Start termination point identifier.
- End termination point identifier.

- Date of measurement performed.
- Name of test operator (in English) for start termination point.
- Name of test operator (in English) for end termination point.

***Laser Source Specification for Start Optical Termination Point***

- Manufacturer.
- Type.
- Option(s) installed.
- Serial number.
- Last date of calibration.

***Laser Source Specification for End Optical Termination Point***

- Manufacturer.
- Type.
- Option(s) installed.
- Serial number.
- Last date of calibration.

***Power Meter Specification for Start Optical Termination Point***

- Manufacturer.
- Type.
- Option(s) installed.
- Serial number.
- Last date of calibration.

***Power Meter Specification for End Optical Termination Point***

- Manufacturer.
- Type.
- Option(s) installed.
- Serial number.
- Last date of calibration.

***OTDR Measurement Specifications for Start Optical Termination Point***

- Manufacturer.
- Type.
- Option(s) installed.
- Serial number.
- Last date of calibration.

***OTDR Measurement Specifications for End Optical Termination Point***

- Manufacturer.
- Type.

- Option(s) installed.
- Serial number.
- Last date of calibration.

*Dispersion and PMD Measurement Specifications (if not supplied with factory drum test sheet)*

- Manufacturer.
  - Type.
  - Option(s) installed.
  - Serial number.
  - Last date of calibration.
- 5.2. The results of the attenuation and OTDR measurements shall be gathered on the fiber section acceptance form as shown below. This acceptance sheet shall be given as a paper copy and as an electronic copy (Microsoft Excel 2003) on the CD-ROM.
- 5.3. The print-out of the OTDR measurements in both directions for both 1310 nm and 1550 nm shall be included in the fiber acceptance report and an electronic copy of the measurement files on the CD-ROM including a full copy of the viewer of these measurement files (HP, Siemens, Anritsu or other).

## Example Sheet

Section Start optical termination point (A) To End optical termination point (B)

<b>cable section ID</b>	
<b>Start point ID</b>	

<b>End point ID</b>	
---------------------	--

Fibre No.	1550 nm				1310 nm			
	A to B (dB)	B to A (dB)	Difference Loss (dB)	Average (dB)	A to B (dB)	B to A (dB)	Difference Loss (dB)	Average (dB)
1	-5.21	-4.94	0.27	-5.08	-7.36	-7.95	0.59	-7.66
2	-4.98	-4.79	0.19	-4.89	-7.12	-7.71	0.59	-7.42
3	-5.64	-5.28	0.36	-5.46	-7.77	-8.32	0.55	-8.05
4	-4.76	-4.63	0.13	-4.70	-6.77	-7.35	0.58	-7.06
5	-5.13	-4.92	0.21	-5.03	-7.33	-7.82	0.49	-7.58
6	-5.23	-5.10	0.13	-5.17	-7.32	-7.79	0.47	-7.56
7	-5.28	-5.11	0.17	-5.20	-7.58	-7.98	0.40	-7.78
8	-4.99	-4.67	0.32	-4.83	-7.14	-7.79	0.65	-7.47
9	-5.40	-4.96	0.44	-5.18	-7.51	-7.90	0.39	-7.71
10	-5.40	-5.14	0.26	-5.27	-7.51	-8.15	0.64	-7.83
11	-4.92	-4.75	0.17	-4.84	-7.11	-7.39	0.28	-7.25
12	-5.16	-5.01	0.15	-5.09	-7.51	-7.94	0.43	-7.73
13	-5.01	-4.62	0.39	-4.82	-7.06	-7.38	0.32	-7.22
14	-5.60	-5.33	0.27	-5.47	-8.06	-8.62	0.56	-8.34
15	-5.44	-5.27	0.17	-5.36	-7.85	-8.35	0.50	-8.10
16	-5.28	-5.06	0.22	-5.17	-7.57	-7.96	0.39	-7.77
<b>Averaged</b>	-5.21	-4.97	0.24	-5.09	-7.41	-7.90	0.49	-7.66
<b>Mean</b>	-5.09		0.24		-7.66		0.49	

<b>Physical cable length as obtained by OTDR</b>	20.01	km
<b>Number of splices from A to B</b>	9.00	pcs

**Acceptance criteria**

- 1 all averaged values per fibre (column G and K) below required total allowable loss
- 2 differences of measurements in both directions may not differ more than 0.5 dB at 1550 nm and not more than 0.7 dB at 1310 nm for each fiber

**Requirements:**

	1550 nm	1310 nm
Cable Attenuation per km (dB):	0.23	0.35
Total Physical Cable Length (km):	20.01	20.01
Splice Loss Mean Value (dB):	0.05	0.05
Total Number of Splices:	9	9
Maximum Connector Loss (dB):	0.50	0.50
Total Number of Connectors:	2	2
Allowance for short section (dB):	0.00	0.00
<b>Total Allowable Loss (dB):</b>	<b>6.05</b>	<b>8.45</b>

Approved by Contractor Representative:	Witnessed and signed PMC Representative	Accepted and signed MoICT Representative
Signature: _____	Signature: _____	Signature: _____
Name: _____	Name: _____	Name: _____
Date: _____	Date: _____	Date: _____

## **ANNEX I : AS-BUILT SPECIFICATIONS FOR FIBER INSTALLATION**

### **As built specification GIS & AutoCAD for fiber installation**

#### **Requirements for GIS data submitted by Ministry of Digital Economy and Entrepreneurship MODEE**

GIS data for Broadband is a consistence of integrated GIS layers represents GIS database structure of Broadband Sector, and these data are classified to:

- 1- **Operational GIS Layers** ( Duct cables, Arial cable, Duct rout, Connection point, Aggregate, Manhole, Hand hole, Junction, poles, pull box, splice )
- 2- **Assistant GIS Layers** (Administrative Boundaries, Landmarks, Streets, Base Maps...)

A set of general requirements and technical rules apply to any submitted GIS data in order to match our needs in this field.

#### **1- General Requirements:**

- 1- All GIS data submitted should be in ESRI format (Geo database & Shape File)
- 2- GIS data should be referenced in the same Coordinate system that is used by MODEE which is the JTM.
- 3- The extent of submitted data should be covering the concerned area or the projected area.
- 4- The submitted data should be checked carefully and to be more close to our requirements before delivery.
- 5- It is preferred to receive a sample copy for checking (one copy in case if more than one copy should be submitted) of as built data until the final ok is given for submitting a final copy.
- 6- All GIS data that is not produced by contractors should be obtained legally (eg. Base Maps, Streets...).
- 7- The digital copy of as built data should be delivered on a C.D.
- 8- The hard copy should be delivered

#### **2- Technical Rules:**

GIS layers contained from two components (Spatial and Attribute information), so when we use a GIS as a tool to reflect Broad Band network information, we need to apply a set of rules and standards to govern this process.

#### **Spatial Information:**

The spatial information very important, in ArcGIS, so there are several rules and restrictions govern the behaviors and relationships between features in the same layer or features of different layers. The data should be topologically clean and free from topological errors (e.g., unsnapped dangling nodes, extra nodes, or unnecessary intersections).

The main rules and restrictions that should be taken in consideration when we dealing with GIS broadband data are:

- 1- **Connectivity:** Lines in networks should be snapped to each other and no dangles should be appeared at connection points of lines. Also nodes (accessories or manhole) should be snapped to lines.
- 2- **Behavior of Features:** Nodes split lines where it is located on and make it two different features.
- 3- **Adjacency:** Features mustn't overlap or having gaps (slivers) when we dealing with polygons layers.
- 4- **Coincidence:** Broadband lines should be appeared within streets boundaries and in the Wright side (right or left) of street with no crossing of parcels or plots.

### **Attribute Information:**

Attribute information reflects the description of features (Duct lines, Arial lines, manholes and fittings), so it is very important to be filled correctly as follow:

- 1- All records of attribute table should be filled completely; any empty values will be meaningless.
- 2- Fields format should be the same as in GIS database structure of MODEE.

### 3- **Base Map (Polygons)**

The attribute information of *should contain DLS Key*

4- *Landmarks* layer should contain the following fields: (Landmark Type and Landmark Name (English and Arabic)).

### 5-**Streets (Polygons).**

The attribute information of *Streets* layer should contain the following fields: (Street Name (English and Arabic)).

### **GIS layers used in NBN Program:**

**All layers that will be taken from governmental institutions should be legal for example: DLS, street ....**

<b>Layer Name</b>	<b>Layer Type</b>	<b>Layer Description</b>
Duct Route	Line	This layer contains all routes That under ground
Arial Cable	Line	The cable which is over head on poles
Duct cable	Line	The cable which is under ground



Aggregate	Point	This layer represent the place where cables distribute from
Aggregate Boundary	polygon	This layer represent the boundary of each aggregate
Manhole	Point	Cables get through and using for Duct cables
Hand Hole	Point	Cables get through and using for Duct cables
Connection Point	Point	School, government entity or any object will be connected
Poles	Point	Where over head cables connect to gather
Pull Box	Points	The end place of the cable when entering the connection point
Splice	Point	Where two or more cables connect to gather
Streets	Line	Base map
DLS	Area	Parcels of the land (base map)

### Attribute Data

Layer Name	Field	Notes
Duct Route	Route id Number of duct Available duct Status Measured Length	String Integer Integer Text Double
Arial Cable	Cable id Cable type Cable size Dedicated fiber Measured Length	String Text Integer Integer Double
Duct Cable	Cable id Cable type Cable size Dedicated fiber Measured length	String Text Integer Integer Double
Aggregate	Aggregate id Name (Arabic) ODF_Cable Coordinate	String Text String Double
Aggregate Boundary	Aggregate number	Integer

Manhole	MH number Status MH id Coordinate	String Text String Double
Hand Hole	HH number Status HH id Coordinate	String Text String Double
Connection point	Connection point id Arabic Name English name Coordinate Fiber-Allocation-Tx Fiber-Allocation-Rx	String Text Text Double String String
Poles	Poles id Poles number Coordinate	String String Double
Pull Box		
Splice	Splice id Splice number Splice size Splice type	String String Integer Integer
DLS	DLD key	String
Street	Arabic Name English name	Text Text

An electronic copy in GIS (ESRI format) shall be provided.

### ***As-Built Specifications for Fiber Installation (AutoCAD)***

*“As-Built” is defined as the drawings and document showing the final configuration of optical fiber cables and accessories.*

1. For each site (optical termination point) and route “As-Built” Drawing shall be supplied.
2. Two copies of AutoCAD As-Built drawings for:
  - (Civil work).
    - Civil Work routes, including manholes, Hand holes, Pull Box, Entity location and poles with their numbers.
    - Distance between the manholes and Hand holes.
    - The distance between the routes and streets edge and the location of the route according to street edge (right or left).
    - Number of ducts in each section.
    - New Entities Locations with their names and numbers.
    - Aggregate points Locations with their numbers (Label).
  - Optical fiber distribution plan.
    - Splice Boxes location.
    - Indicate the cable type (Ring or Access) (ADSS or Duct).

- Cables number, size, and used strands from the main cable (all these data should be applied in each section between two splice boxes or between splice and the ODF).

Ex:

Between MH.16 & MH.17

Cable ID : 5  
 Cable Size : 48  
 Used Fiber : 28 (1-16),(19-22),(33-40)  
 Cable length : 309 m.  
 Splice ID : Sp-08 in MH 017.

- OTDR or Power Meter test result for each new entity at 1310 and 1550.
- Cable length according to the OTDR reading in each section between two splice boxes and between the entities and aggregate points
- Strands spares locations with their numbers and there distance to AGG.
- Interior details for Manholes and Handholes, showing how each ducts are used and the direction of in and out cable.

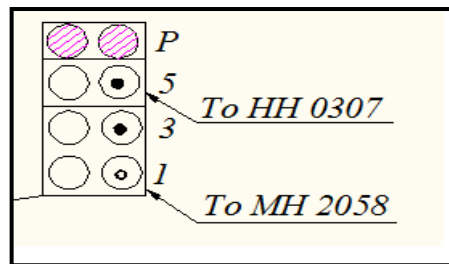

Ex:

- The length of spare coil inside Manholes and Handholes.
- All new entities with their id and Name, and used strand for each.
- All Manholes, Hand holes, splice and poles with their numbers (label).
- Use a special symbol for aggregate point clarifying existing ODFs with their strands (The Aggregations cabinets Interior details) .

“As-Built” drawings and documents shall be provided in soft and hard copy on (A1) paper size.

3. The symbols used by the Contractor on As-Built drawings shall comply with the legend and symbols and layer mapping as shown in the specification provided or to be approved by the Engineer.
4. Samples of the As-Built drawings and documents are to be submitted to the Engineer for approval prior to production of the final As- Built.
5. Sufficient identification marks and information are to be used to facilitate and indicate the exact location of the manholes, joints and the cable routes.
6. Manholes, Handholes, and pull boxes offset is to be clearly shown in the As-Built documents.

## **ANNEX J: SERVICE LEVEL AGREEMENT (SLA)**

The contractor's prices in his BOQ shall include all costs incurred by him to provide the following terms for the Service Level Requirements (SLR):

### **A. Procedural:**

1. The Contractor has to assign a Manager/Supervisor acting as a contact person and problem solver, including emergency phone number(s) open 24 hours, Fax number, and specified office location and proper warehousing facilities.
2. MoDEE is to specify a contact person authorized to report and follow-up all maintenance activities until full clearance of the reported issue, including emergency phone number open 24 hours, Fax number.
3. Steps required to initiate a repair maintenance process:
  - MoDEE informs the Contractor of the problem, by MoDEE's nominated person only.
  - The Contractor team shall be available on site within 6 hours to determine the cause of fault, supported with the necessary skills and equipment's.
  - Accordingly the MoDEE shall inform the concerned authorities/schools directors, entities ... etc. of the possible visit(s) to their sites by the contractor.
  - Once the fault is determined, a design for the maintenance work shall be provide to the contractor with the required work procedures.
  - During repairs MoDEE should be informed of any deviations to the agreed upon solution. Informing MoDEE of the above occurrence.
  - Upon repair completion, the Contractor should call for test acceptance and finalize the required documentation, including the As-built modifications resulting from such repairs, for future incorporation to the As-built by MoDEE.

### **B. Average Intervention Time**

The time span stated here is of course variable and basically depends on the specific conditions linked to the fault: ADSS Cable or In-Duct, night, week-end, ease of access ... etc.

1. The Contractor's response time shall be 1 hour after MoDEE inform him of the fiber fault.
2. The Contractor's maintenance team shall be available 24/7.
3. For duct routes the repairing for the Fiber works shall start within two hours after the civil works are done.
4. The Contractor shall inform the MoDEE's representative to attend the repair tests and shall provide him with documented reports that shall reflect the As-Built.
5. The contractor shall comply with the response and resolution times to repair cuts as shown in table-1 and 2 for the Fiber Cuts repair, noting that if the contractor doesn't comply with these times; then he shall pay to MoDEE the penalties shown in table-4:

**a. Duct Cable:**

ITEM	Description	Response Time (Available on Site Including All Permits)	Resolution Time (Time To Complete works)
1	Repairing and replacing the existing damaged ducts and cable for distance <b>up to 350m</b> with all related civil and Fiber works (defined in the tender documents)	Three Hours	One Day.
2	Repairing and replacing the existing damaged ducts and cable for distance <b>more than 350m</b> with all related civil and Fiber works	Three Hours	Two Days
3	F.O cable Installation and Splicing up to 500m (with all needed works defined in the tender documents).	Three Hours	Five Hours
4	F.O cable Installation and Splicing for more 1000m (with all needed works defined in the tender documents).	Three Hours	Seven Hours

Table-1

**b. ADSS Cable:**

ITEM	Description	Response Time (Available on Site Including All Permits)	Resolution Time (Time To Complete works)
1	F.O cable Installation and Splicing up to 48 strands.	Three Hours	One Day for the first 1000 m
2	F.O cable Installation and Splicing for more than 1000m.(with all needed works )	Three Hours	Five Hours for every 300 m above the First 1000m

Table-2

**c. ADSS Routes Transferring:**

	Description	Response Time (Available on Site Including All Permits)	Resolution Time (Time To Complete works)
1	F.O cable Installation and Splicing.	Three Hours	Three Hours for every 200 m

Table 2 -1

**d. Connecting New Entities:**

	Description	Permits	Resolution Time (Time To Complete works)
1	Civil Work, F.O cable Installation and Splicing and fiber termination. For distance less than 100 m.	10 days to get permits.	Three Days.
2	Civil Work, F.O cable Installation and Splicing and fiber termination. For distance between 100 m and 500m.	10 days to get permits.	Five Days

Table-3

**e. Penalties for cut repairs:**

Priorities: priorities in implementing works should be according to the number of entities affected by any problem on the network or the level of importance of these entities based on the following table:

Priority Level	Definition
1	<ul style="list-style-type: none"> <li>▪ Fiber cut for any SGN entities</li> <li>▪ Fiber cut on a main route.</li> </ul>
2	<ul style="list-style-type: none"> <li>▪ Fiber cut on a route (less than 5 schools are affected).</li> </ul>
3	<ul style="list-style-type: none"> <li>▪ Connecting New Entity</li> </ul>

Table-3

MoDEE is entitled to apply penalties on the bidder in accordance with the level of importance for the work and for a certain duration as shown in table-4, if the bidder doesn't fulfill the cut repair within the time frame shown in this table; then MoDEE shall perform all cut repairs as it sees fit or through a third party to fix the problem, and according to the following criteria:

Priority	Work Definition	Penalties
1	<ul style="list-style-type: none"> <li>▪ Fiber cut for any SGN entities</li> <li>▪ Fiber cut on a main route (more than 5 schools are affected)</li> </ul>	A penalty of (150) JD will be applied for each day pass the resolution time, and will continue for 1 day, after that, a third party will be called to fix the problem on contractor's expenses.
2	<ul style="list-style-type: none"> <li>▪ Fiber cut on a route (less than 5 schools are affected).</li> </ul>	A penalty of (150) JD will be applied for each day pass the resolution time, and will continue for 1 day, after that, a third party will be called to fix the problem on contractor's expenses.
3	<ul style="list-style-type: none"> <li>▪ Connecting New Entity</li> </ul>	A penalty 10 % of the Fiber and Civil Work Cost for connecting this entity will be applied for each day pass the resolution time, and will continue for 1 day, after that, a third party will be called to fix the problem on contractor's expenses.

Table-4

## **ANNEX K : SAFETY REQUIREMENTS OF EDCO**

### **متطلبات شركة توزيع الكهرباء**

بالإضافة الى ما هو وارد ادناه، فانه يترتب على المقاول قبل المباشرة بأعمال تعليق الكوابل على الأعمدة التابعة لشركة توزيع الكهرباء ان يكون على دراية تامة بكافة إجراءات السلامة العامة والمتطلبات الفنية المتبعة لدى الشركة وان يستفسر عنها ويحصل بنفسه عليها ولن يكون صاحب العمل مسؤولاً عن أي عطل او ضرر قد يلحق بالمقاول نتيجة لعدم تفهمه او اتباعه لهذه الشروط.

1. يضع المقاول في الوقت المناسب خطة عمل أولية واضحة يبين فيها المواقع التي يرغب بتركيب كوابل الألياف الضوئية على أعمدة شركة الكهرباء، موضحا فيها أولويات التنفيذ من حيث المناطق الجغرافية وعليه ان يعلم شركة الكهرباء عن المنطقة او المناطق التي يرغب مباشرة العمل بها قبل شهرين على الأقل من تاريخ المباشرة بالعمل ، لتتمكن شركة الكهرباء من اتخاذ أي إجراءات تلزم لتدعيم وتقوية أعمدتها قبل انتهاء المدة المشار إليها أعلاه بحيث يتمكن المقاول من انجاز الأعمال الخاصة به دون تأخير ، وفي الحالات التي تتطلب فترات زمنية أطول بناء على تقديرات شركة الكهرباء او في الحالات التي تتطلب تركيب أعمدة إضافية فانه يتم الاتفاق على هذه المدة في حينه.

2. يحق لشركة الكهرباء على ضوء الدراسة الفنية لخطة العمل الأولية التي يقدمها المقاول ان ترفض طلب المقاول لتركيب أي من الكوابل شريطة تقديمها اسباب رفض مقتعة لوزارة الاتصالات ومقاولها، وإذا اتضح انه ليس بالإمكان تلبية طلب المقاول، فعلى كافة الأطراف دراسة البدائل المختلفة والاتفاق عليها لتمكين المقاول من انجاز الشبكة.

3. تقوم شركة الكهرباء بتقديم المشورة الفنية اللازمة لصاحب العمل ومقاوليه خلال مرحلة تركيب الكوابل، لتتأكد شركة الكهرباء من ان أعمال التركيب تتم وفقا لمتطلباتها وحسب الشروط الفنية وإجراءات السلامة المتبعة لديها.

4. تقوم شركة الكهرباء بالإشراف على الأعمال التي يقوم بها المقاول، ويحق لشركة الكهرباء إبلاغ وزارة الاتصالات فوراً عن أي اخطاء او مخالفات في اعمال التركيب التي يتم انجازها، كما يحق لها الطلب من وزارة الاتصالات ابعاد أي من العاملين لديها او لدى أي من مقاوليها إذا تبين لها انهم يخالفون تعليمات الشركة او لا يتبعون متطلبات السلامة التي تعتمدها الشركة.

5. يحق للمقاول أو أي من موظفيه أو تابعيه الذين يتولون تركيب الكوابل المتفق على تركيبها والوصلات الخاصة بها وأعمال الصيانة المتعلقة بها الصعود على أعمدة الشبكة الكهربائية الخاصة بشركة الكهرباء ذات الضغط المنخفض او المتوسط الى مستوى يصل إلى اعلى نقطه من الكوابل الخاصة بالمقاول فقط ، ولا يجوز لأي منهم تجاوز هذا الحد الى الاعلى باي جزء من اجزاء الجسم او بأي نوع من المعدات أو الأجهزة ولأي سبب من الأسباب كما لا يجوز لهم العمل على غير الكوابل المتفق عليها ، وعلى ان يتقيد المقاول أو أي من موظفيه بتطبيق قواعد السلامة العامة المعمول بها لدى شركة الكهرباء، ويعتبر المقاول مسؤولاً مسؤولية منفردة عن اية اضرار قد تلحق بشركة الكهرباء واملها بالإضافة لمسؤوليته عن اية اضرار قد تلحق بموظفيه ومستخدميه و مقاوليه واي تابع له.

6. يقوم المقاول بتركيب الكوابل على اقصى ارتفاع ممكن على ان لا يقل عن خمسة امتار من اخفض نقطه من هذه الكوابل ، وذلك في حالة عدم تقاطع الكيبل مع الشوارع، و في حالة التقاطع فان المسافة يجب ان لا تقل عن ستة امتار (او حسب تعليمات المهندس) شريطة ان لا تقل المسافة بين الكوابل المتفق على تركيبها والشبكات ذات الضغط المنخفض عن مسافة 1 متر ، والمسافة بين الكوابل المتفق على تركيبها والشبكات ذات الضغط المتوسط عن مسافة 3 متر ، او حسب ما يتم الاتفاق عليه مع شركة الكهرباء في حينه ، و لا يحق للمقاول اثناء عمليات الصيانة وتركيب الوصلات الاقتراب من الشبكات الكهربائية لمسافة تقل عن المسافة المذكورة اعلاه باي جزء من اجزاء الجسم او باي نوع من المعدات أو الأجهزة ولا يحق له الوصول الى الأسلاك التابعة لشبكات شركة الكهرباء .

وفي جميع الأحوال لا تتحمل شركة الكهرباء أية مسؤولية ناجمة أو مترتبة عن أعمال المقاول وتابعيه وفقاً لما جاء في البند السابق.

7. لا يجوز للمقاول تركيب أكثر من كيبل واحد على نفس العمود.

8. بالنظر لخطورة العمل على الشبكات الحية وما يتطلب ذلك من الصرامة والدقة في التعامل مع العاملين على هذه الشبكات فان لشركة الكهرباء او لمهندسيها صلاحية الرقابة (ان رأى ضرورة لذلك) على كواذر المقاول او كواذر مقاولييه الذين يتولون تركيب الكوايل و/او الوصلات و/او صيانة الكوايل المركبة على اعمدة شركة الكهرباء، والذين يتولون التعامل مع اجهزة شركة الكهرباء الفنية او الإدارية في الامور التي تتعلق بهذا المشروع، ودون ان تؤثر صلاحية الرقابة تلك على مسؤوليات المقاول. وبناء عليه يحق لشركة الكهرباء ان تطلب من وزارة الاتصالات استبعاد أي موظف من موظفي المقاول في حالة ارتكاب ذلك الموظف لاية مخالفه لتعليمات شركة الكهرباء او الإساءة الى موظفي شركة الكهرباء وعلى الوزارة ان تستجيب لهذا الطلب وعلى شركة الكهرباء تزويد الوزارة بمبررات الاستبعاد لاحقاً.

-----